



# OLP-HEIB 50kW/111kWh

## Air-Cooled Hybrid Energy Storage All-In-One Cabinet

The OLP-HEIB air-cooled hybrid energy storage all-in-one series cabinets are meticulously developed by OLiPower, which is experienced in power electronics, automation, IoT, and AI technologies. The OLP-HEIB are on/off grid energy storage products designed for areas without electricity or with insufficient power supply. They can work with PV systems and generators to form an intelligent microgrid, with functions like peak shaving, backup power, peak & frequency regulation, transformer expansion, and smoothing renewable energy fluctuations, providing users with safe, reliable, economical, and efficient green electricity.



### PRODUCT FEATURES

#### Super Safety

- Self-developed BMS, EMS, and cloud platform to achieve three-level electrical protection of "Pack - Cluster - Cabinet".
- Comprehensive fire detection and multiple fire protection. The entire cabinet, detected by combustible gas, smoke, temperature, and waterlogging sensor, is equipped with aerosol fire extinguishing system, and water sprinkler system.
- AI data diagnosis provides early warnings based on the trend change rate of operation data.

#### Intelligent & Efficient Operation

- Designed with high energy density to save more space.
- Form an intelligent microgrid with PV & generator to provide a green, efficient, and uninterrupted power supply.
- Support seamless switching between on-grid and off-grid mode within 20 milliseconds, ensuring the stable operation of the load.

#### Flexible Deployment

- Support to be installed by hoisting and forklift, and available for side-by-side and back-to-back deployment.
- Flexible expansion capacity, supporting up to 10 DC units operating in parallel and 4 AC units operating in parallel.
- Pre-installation and commissioning in the factory, plug-and-play on-site.

#### Smart Maintenance

- Providing the function of demand control, anti-backflow and transformer overload protection to make the on-grid operating safely.
- Providing all-time cloud monitoring, remote configuration, and OTA to keep the system in the best condition.

## TECHNICAL PARAMETER

Model	OLP-HEIB-V541_E111_P50-AO	
Battery System	Cell Type	LFP
	Cell Parameter	3.22V/206Ah
	Cell Configuration	1P168S
	Rated Energy	111kWh
	Rated Voltage	540.96V
	Voltage Range	470.4 ~ 613.2V
	Rated Current	103A
	Max. Current	200A
PV Input	Max. Input Power	75kW
	Start-up Voltage	135V
	MPPT Voltage Range	200 ~ 950V
	Numbers of MPPT	4
	Numbers of DC Inputs per MPPT	2
	Max. Input Current	30A*4
On-grid	Rated Power	50kW
	Rated Voltage	3L/N/PE; 220/380V; 230/400V; 240/415V
	Max. Current	83A
	Frequency	50/60Hz
	Power Factor	0.8leading ~ 0.8lagging
	Harmonic	<3% @ Rated Power
Off-Grid	Rated Power	50kW
	Rated Voltage	3L/N/PE; 220/380V; 230/400V; 240/415V
	Max. Current	83A
	Frequency	50/60Hz
	On/Off-grid Switch Time	<20ms
	Harmonic	<3% @ Linear load
SyStem Parameters	Thermal Management	Air-conditioner
	Fire Supression System	Heat/Smoke Detector, Aerosol
	Communication	LAN/WiFi/4G
	Generator Connection	Supported, Multifunction Dry Contact Relay
	Security Protection	Access Control System, Waterlogging Sensor, Fire Protection System
	Dimension(W*D*H)	Cabinet:700*1313*2200(mm); Hybrid Storage Inverter:760*290*490(mm)
	Weight	About 1700kg
	IP Rating	Cabinet:IP54; Hybrid Storage Inverter:IP65
	Operating Temperature	-20 ~ 50°C
	Humidity	0~95%RH(No condensation)
	Latitude	≤3000m
	Certification	UN38.3; IEC62619; IEC61000

## INSTALLATION DIMENSIONS

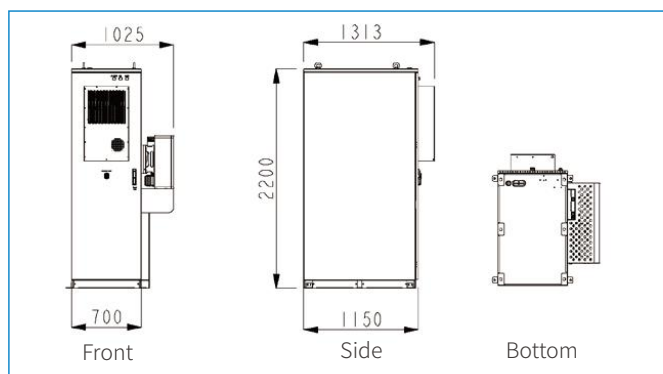

## TYPICAL APPLICATION

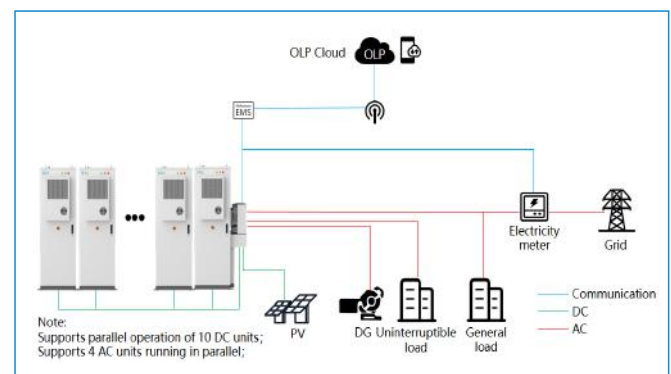

**OLiPower Energy & Automation Technology Co., Ltd**

1001, Block A, Building 2, Shangzhi Technology Park, No.380 Guangming Avenue,  
Tangwei Community, Fenghuang Street, Guangming District, Shenzhen City, Guangdong Province

+86 (755) 2650 8686    sales@olipower.cn

\*OLiPower reserves the right of final interpretation, and is subject to modify without prior notice.



Welcome to follow  
Discover  
more company information