

OLP-EIB-V541_E111_P50-A001 光储一体柜

用户手册

OLP- EIB-V541_E111_P50-A001 AII-In-One ESS Cabinet

User Manual



欧力普能源与自动化技术有限公司
OLiPower Energy & Automation Technology Co.,Ltd

OLP 50kW/111kWh 风冷光储一体柜用户手册 OLP 50kW/111kWh Air Cooling Energy Storage Cabinet All-In-One Product User Manual	文件编号: OLP-EIB-V541_E111_P50-A001-1001 Document number: OLP-EIB-V541_E111_P50-A001-1001	版本: V0.1 Version:V0.1	Page 1 of 97
© 欧力普能源与自动化技术有限公司 2024 保留所有权利 © OLiPower Energy & Automation Technologies 2024 All rights reserved.	地址: 深圳市光明区凤凰街道塘尾社区光明大道 380 号尚智科技园 2 栋 A 座 10 楼 Address: 10th Floor, Block A, Building 2, Shangzhi Science and Technology Park, No. 380 Guangming Avenue, Tangwei Community, Fenghuang Street, Guangming District, Shenzhen, China.		Tel: +86 (755) 2650 8686 E-mail: sales@olipower.cn

文档审批

Document Approval

	姓名 Name	部门 Dept	日期 Date	签字 Signature
批准 Released		系统集成部		Sgd.
核稿 Checked		系统集成部		Sgd.
拟稿 Prepared	Zhang Yuan	系统集成部	2025-03-12	Sgd. 张渊

版本更新记录

Version Update Record

日期 Date	版本 Edition	更新说明 Update Explanation	作者 Author
2025. 03. 12	V0.1	初版 First edition	张渊 Zhang Yuan

目录 Catalogue

- 1. 缩略语 Abbreviations 5
- 2. 安全注意事项 Safety Precautions 6
 - 2.1. 安全公告 Safety Notice 6
 - 2.1.1. 使用公告 Usage Notice 7
 - 2.1.2. 静电保护 Static Protection 8
 - 2.1.3. 接地要求 Grounding Requirements 9
 - 2.1.4. 防潮保护 Moisture Protection 9
 - 2.1.5. 安全警告标签设置 Security Warning Label Setting 9
 - 2.1.6. 设备运行中的测量 Measurement During Equipment Operation 10
 - 2.2. 操作员要求 Operator Requirements 10
 - 2.3. 运行环境要求 Operating Environment Requirements 11
- 3. 产品说明 Product Introduction 11
 - 3.1. 产品简介 Product Overview 11
 - 3.1.1. 产品型号 Product Model 11
 - 3.1.2. 产品铭牌 Product Nameplate 12
 - 3.1.3. 产品规格 Product Specifications 13
 - 3.1.4. 操作模式 Operation Modes 16
 - 3.2. 系统原理图 System Schematic Diagram 20
 - 3.3. 外观尺寸 Appearance Dimensions 21
 - 3.3.1. 外观 Appearance 21
 - 3.3.2. 尺寸 Dimension 22
 - 3.3.3. 显示面板 Display Panel 22
 - 3.4. 部件说明 Component Description 23
 - 3.4.1. 储能系统 Energy Storage System 25
 - 3.4.2. 热管理系统 Thermal Management System 34
 - 3.4.3. 消防系统 Fire Protection System 36
 - 3.4.4. 门禁系统 Access Control System 37
 - 3.4.5. 水浸系统 Flood Protection System 37
 - 3.4.6. 混合逆变器 Hybrid Inverter 37
- 4. 安装 Installation 39
 - 4.1. 安装准备 Installation Preparation 40
 - 4.1.1. 安装工具 Installation Tools 40
 - 4.1.2. 安装环境 Installation Environment 40
 - 4.2. 搬运 Handling 41
 - 4.2.1. 柜体重心 Center Of Gravity 43
 - 4.2.2. 搬运方式 Handling Method 43
 - 4.3. 开箱检查 Open Box Inspection 44

4.4.	柜体安装 Cabinet Installation.....	45
4.4.1.	逆变器安装 Inverter Installation.....	46
4.4.2.	机柜安装 Cabinet Installation.....	48
4.4.3.	安装孔位 Installation Hole Position.....	50
4.4.4.	地基 Foundation.....	50
4.4.5.	固定 Fixing.....	51
4.5.	电气安装 Electrical Installation.....	52
4.5.1.	接线检查 Wiring Inspection.....	53
4.5.2.	接线说明 Wiring Instructions.....	54
4.5.3.	电气接线图 Electrical Wiring diagram.....	56
4.5.4.	AC 连接 AC Connection.....	57
4.5.5.	安装监控设备 Install monitoring equipment.....	62
4.5.6.	电表和 CT 连接 Connect Meter and CT.....	63
4.5.7.	通讯连接 Communication Connection.....	65
4.5.8.	PV 组串连接 PV String Connection.....	79
4.5.9.	电池电缆线连接 Battery Cables Connection.....	84
5.	调试与运行 Debugging And Operation.....	85
5.1.	检查 Inspection.....	85
5.2.	操作说明 Operating Instructions.....	86
5.2.1.	开机 Startup.....	86
5.2.2.	逆变器监控配置 Inverter Monitoring Setting.....	87
5.2.3.	关机 Shutdown.....	90
6.	故障处理 Fault Handling.....	91
6.1.	故障一览表 Fault List.....	91
7.	日常保养与维护 Daily Maintenance And Upkeep.....	94
7.1.	日常检查项目 Daily Inspection Items.....	95
7.2.	定期检查项目 Regular Inspection Items.....	95
8.	设备清单 Equipment List.....	96

1. 缩略语 Abbreviations

缩略语 Abbreviation	中文 Description - CN	英文 Description - EN
OLP	欧力普能源与自动化技术有限公司	Olipower Technologies Co., Ltd
BESS	电池储能系统	Battery Energy Storage System
BMS	电池管理系统	Battery Management System
BMU	电池管理单元	Battery Management Unit
BSU	电池采样单元	Battery Sampling Unit
BOL	生命周期起始	Beginning of Life
CAN	控制器局域网总线	Controller Area Network
DC	直流电	Direct Current
DOD	电池放电深度	Depth of Discharge
EOL	生命周期结束	End of Life
ESS	储能系统	Energy Storage System
FAT	工厂验收测试	Factory Acceptance Testing
HMI	人机界面	Human Machine Interface
IP	防护等级	Ingress Protection
kVA	千伏安	Kilo-Volt Ampere
kWh	千瓦时	Kilo-Watt Hour
MPPT	最大功率点跟踪器	Maximum Power Point Tracker
MCB	主断路器	Main Circuit Breaker
MCCB	塑壳断路器	Moulded Case Circuit Breaker
ms	毫秒	millisecond
MSD	手动维修开关	Manual Service Disconnect
PCS	储能变流器	Power Conversion System
PDU	配电单元	Power Distribution Unit
SAT	现场验收测试	Site Acceptance Testing

缩略语 Abbreviation	中文 Description - CN	英文 Description - EN
OLP	欧力普能源与自动化技术有限公司	Olipower Technologies Co.,Ltd
SCADA	监控与数据采集系统	Supervisory Control and Data Acquisition
SOC	电池荷电状态	State Of Charge
SOE	电池剩余能量状态	State Of Energy
SOH	电池健康状态	State Of Health
SOP	电池功率状态	State Of Power
UPS	不间断电源	Uninterruptible Power Supply

表 1 缩略语

Table 1 Abbreviations

2. 安全注意事项 Safety Precautions

本章介绍安全公告。在对设备进行任何操作之前，请仔细阅读用户手册，遵循操作和安装说明，并遵守所有危险、警告和安全信息，以避免不正常操作造成人身伤害和设备损坏。

This chapter introduces safety notices. Before performing any operation on the device, please carefully read the user manual, follow the operating and installation instructions, and comply with all danger, warning, and safety information to avoid personal injury and equipment damage caused by abnormal operation.

2.1. 安全公告 Safety Notice

本节主要介绍操作和维护时的安全注意事项。有关详细信息，请参阅相关章节中的安全说明。

This section mainly introduces safety precautions during operation and maintenance. For detailed information, please refer to the safety instructions in the relevant sections.



注意安全 Caution!

- 操作前，请仔细阅读本节的公告和操作说明，以免发生事故。
- Before operation, please carefully read the announcement and operating instructions in this section to avoid accidents.
- 用户手册中的提示，如“危险”、“警告”、“小心”等，并不包括所有的安全公告。

OLP 50kW/111kWh 风冷光储一体柜用户手册 OLP 50kW/111kWh Air Cooling Energy Storage Cabinet All-In-One Product User Manual	文件编号: OLP-EIB-V541_E111_P50-AO01-1001 Document number: OLP-EIB-V541_E111_P50-AO01-1001	版本: V0.1 Version:V0.1	Page 6 of 97
© 欧力普能源与自动化技术有限公司 2024 保留所有权利 © Olipower Energy & Automation Technologies 2024 All rights reserved.	地址: 深圳市光明区凤凰街道塘尾社区光明大道 380 号尚智科技园 2 栋 A 座 10 楼 Address: 10th Floor, Block A, Building 2, Shangzhi Science and Technology Park, No. 380 Guangming Avenue, Tangwei Community, Fenghuang Street, Guangming District, Shenzhen, China.		
	Tel: +86 (755) 2650 8686 E-mail: sales@olipower.cn		

它们只是操作时安全公告的补充。

- The prompts in the user manual, such as "Danger", "Warning", "Caution", etc., do not include all safety notices. They are just supplements to safety notices during operation.
- 任何因违反一般安全操作要求或设计、生产和使用的安全标准而造成的设备损坏将超出产品保修范围。
- Any equipment damage caused by violation of general safety operation requirements or safety standards for design, production, and use will be beyond the scope of product warranty.

2.1.1.使用公告 Usage Notice



危险 Danger

不要触摸与电网相连的端子或导体，以避免致命风险！

Do not touch terminals or conductors connected to the power grid to avoid fatal risks!



警告 Warning

设备内部没有操作部件。请不要自己打开系统外壳，否则可能会导致触电。非法操作造成的系统损坏超出了质保范围。

There are no operating components inside the device. Please do not open the system casing by yourself, otherwise it may cause electric shock. The system damage caused by illegal operations exceeds the warranty scope.



危险 Danger

- 损坏的设备或设备故障可能导致触电或火灾！
- Damaged equipment or equipment malfunctions may result in electric shock or fire!
- 在对设备进行任何操作之前，请目视检查设备是否没有损坏或危险。
- Before performing any operation on the equipment, please visually inspect whether the equipment is damaged or dangerous.
- 检查其他外部设备或电路的连接是否安全。
- Check if the connections of other external devices or circuits are secure.



危险 Danger

在检查或维护之前，如果直流侧和交流侧刚刚断电，则需要等待 20 分钟，以确保设备完全放电，然后才能进行操作。

Before inspection or maintenance, if the DC and AC sides have just been powered

<p>OLP 50kW/111kWh 风冷光储一体柜用户手册 OLP 50kW/111kWh Air Cooling Energy Storage Cabinet All-In-One Product User Manual</p>	<p>文件编号： OLP-EIB-V541_E111_P50-AO01-1001 Document number: OLP-EIB-V541_E111_P50-AO01-1001</p>	<p>版本：V0.1 Version:V0.1</p>	<p>Page 7 of 97</p>
<p>© 欧力普能源与自动化技术有限公司 2024 保留所有权利 © Olipower Energy & Automation Technologies 2024 All rights reserved.</p>	<p>地址：深圳市光明区凤凰街道塘尾社区光明大道 380 号尚智科技园 2 栋 A 座 10 楼 Address: 10th Floor, Block A, Building 2, Shangzhi Science and Technology Park, No. 380 Guangming Avenue, Tangwei Community, Fenghuang Street, Guangming District, Shenzhen, China.</p>		<p>Tel: +86 (755) 2650 8686 E-mail: sales@olipower.cn</p>

off, it is necessary to wait for 20 minutes to ensure that the equipment is completely discharged before proceeding with the operation.

 **警告 Warning**

维修时，应确保所有开关已完全断开，并在断开位置设置警告标志，以避免意外重新连接。

When repairing, ensure that all switches are completely disconnected and set warning signs at the disconnected position to avoid accidental reconnection.

 **警告 Warning**

请不要将手指或工具放入旋转的风扇中，以免造成人身伤害或设备损坏。

Please do not put your fingers or tools into the rotating fan to avoid personal injury or equipment damage.

 **注意安全 Caution!**

不允许液体或其他物体进入机柜。

Do not allow liquids or other objects to enter the cabinet.

 **警告 Warning**

如果发生火灾，请使用干粉灭火器。如果使用液体灭火器，可能会造成触电。

If a fire occurs, please use a dry powder fire extinguisher. If a liquid fire extinguisher is used, it may cause electric shock.

 **警告 Warning**

设备上的标签包含有关安全操作的重要信息。不要撕毁或损坏它们！

The label on the device contains important information about safe operation. Do not tear or damage them!

2.1.2. 静电保护 Static Protection

 **注意安全 Caution!**

为了防止人体静电对敏感元件（如电路板）造成损坏，在接触敏感元件之前，请确保佩戴防静电腕带，另一端接地良好。

To prevent damage to sensitive components (such as circuit boards) caused by human static electricity, please make sure to wear an anti-static wristband and with the other end well grounded before touching sensitive components.

<p>OLP 50kW/111kWh 风冷光储一体柜用户手册 OLP 50kW/111kWh Air Cooling Energy Storage Cabinet All-In-One Product User Manual</p>	<p>文件编号： OLP-EIB-V541_E111_P50-AO01-1001 Document number: OLP-EIB-V541_E111_P50-AO01-1001</p>	<p>版本: V0.1 Version:V0.1</p>	<p>Page 8 of 97</p>
<p>© 欧力普能源与自动化技术有限公司 2024 保留所有权利 © Olipower Energy & Automation Technologies 2024 All rights reserved.</p>	<p>地址: 深圳市光明区凤凰街道塘尾社区光明大道 380 号尚智科技园 2 栋 A 座 10 楼 Address: 10th Floor, Block A, Building 2, Shangzhi Science and Technology Park, No. 380 Guangming Avenue, Tangwei Community, Fenghuang Street, Guangming District, Shenzhen, China.</p>		<p>Tel: +86 (755) 2650 8686 E-mail: sales@olipower.cn</p>

2.1.3.接地要求 Grounding Requirements



警告 Warning

- 泄漏风险高！进行电气连接之前，设备必须接地。接地端子必须接地。
- High risk of leakage! Before making electrical connections, the equipment must be grounded. The grounding terminal must be grounded.
- 安装设备时，必须先将其接地。拆卸装置时，最后必须拆除接地线。
- When installing equipment, it must be grounded first. When dismantling the device, the grounding wire must be removed at the end.
- 不要损坏接地导线。
- Do not damage the grounding wire.
- 设备应永久连接到保护接地。操作前，应检查电气连接，确保设备可靠接地。
- The equipment should be permanently connected to the protective grounding. Before operation, the electrical connections should be checked to ensure reliable grounding of the equipment.

2.1.4.防潮保护 Moisture Protection



注意安全 Caution!

- 湿气侵入可能会导致系统损坏！
- Moisture intrusion may cause system damage!
- 观察以下项目以确保设备正常工作。
- Observe the following items to ensure that the equipment is functioning properly.
- 当环境湿度超过 95%时，不要打开设备的柜门。
- Do not open the cabinet door of the equipment when the environmental humidity exceeds 95%.
- 在潮湿或潮湿的天气下，不要打开设备的柜门进行维护或修理。
- Do not open the cabinet door of the equipment for maintenance or repair in damp or humid weather.

2.1.5.安全警告标签设置 Security Warning Label Setting

- 为了避免意外人员靠近设备柜体或操作不当，在进行安装、日常维护或维修时应遵守以下要求。
- To avoid accidental personnel approaching the equipment cabinet or improper

<p>OLP 50kW/111kWh 风冷光储一体柜用户手册 OLP 50kW/111kWh Air Cooling Energy Storage Cabinet All-In-One Product User Manual</p>	<p>文件编号： OLP-EIB-V541_E111_P50-AO01-1001 Document number: OLP-EIB-V541_E111_P50-AO01-1001</p>	<p>版本：V0.1 Version:V0.1</p>	<p>Page 9 of 97</p>
<p>© 欧力普能源与自动化技术有限公司 2024 保留所有权利 © Olipower Energy & Automation Technologies 2024 All rights reserved.</p>	<p>地址：深圳市光明区凤凰街道塘尾社区光明大道 380 号尚智科技园 2 栋 A 座 10 楼 Address: 10th Floor, Block A, Building 2, Shangzhi Science and Technology Park, No. 380 Guangming Avenue, Tangwei Community, Fenghuang Street, Guangming District, Shenzhen, China.</p>		<p>Tel: +86 (755) 2650 8686 E-mail: sales@olipower.cn</p>

operation, the following requirements should be followed during installation, daily maintenance, or repair.

- 在电池输入端和交流输入端的开关处设置警告标签，以避免开关不当。
- Set warning labels at the switches of the battery input and AC input to avoid improper switching.
- 在操作区域设置警告标志或安全警示带，以避免人身伤害或设备损坏。
- Set up warning signs or safety warning tapes in the operating area to avoid personal injury or equipment damage.
- 维修后，确保拔出设备柜门的钥匙并妥善保存。
- After maintenance, make sure to remove the key to the equipment cabinet door and store it properly.

2.1.6. 设备运行中的测量 Measurement During Equipment Operation

设备中存在高电压。若不慎触碰设备，可能会导致触电。因此，在设备运行中进行测量操作时，操作人员必须有人陪同，并采取保护措施（如戴绝缘手套等）。

There is high voltage in the device. If accidentally touched, it may cause electric shock. Therefore, when conducting measurement operations during equipment operation, the operator must be accompanied by someone and take protective measures (such as wearing insulated gloves).

测量装置必须满足以下要求：

- The measuring device must meet the following requirements:
- 测量装置的量程和操作要求满足现场要求。
- The measuring range and operational requirements of the measuring device meet the on-site requirements.
- 测量装置的连接应正确且标准，以避免电弧。
- The connection of the measuring device should be correct and standardized to avoid arcing.

2.2. 操作员要求 Operator Requirements

- 设备的操作和接线应由合格人员进行，以确保电气连接符合相关标准。
- The operation and wiring of the equipment should be carried out by qualified personnel to ensure that the electrical connections comply with relevant standards.
- 在安装、操作和维护设备之前，操作员必须了解安全公告，知道正确的操作，并接受严格的培训。
- Before installing, operating, and maintaining the equipment, the operator must

<p>OLP 50kW/111kWh 风冷光储一体柜用户手册 OLP 50kW/111kWh Air Cooling Energy Storage Cabinet All-In-One Product User Manual</p>	<p>文件编号： OLP-EIB-V541_E111_P50-AO01-1001 Document number: OLP-EIB-V541_E111_P50-AO01-1001</p>	<p>版本：V0.1 Version:V0.1</p>	<p>Page 10 of 97</p>
<p>© 欧力普能源与自动化技术有限公司 2024 保留所有权利 © Olipower Energy & Automation Technologies 2024 All rights reserved.</p>	<p>地址：深圳市光明区凤凰街道塘尾社区光明大道 380 号尚智科技园 2 栋 A 座 10 楼 Address: 10th Floor, Block A, Building 2, Shangzhi Science and Technology Park, No. 380 Guangming Avenue, Tangwei Community, Fenghuang Street, Guangming District, Shenzhen, China.</p>		<p>Tel: +86 (755) 2650 8686 E-mail: sales@olipower.cn</p>

understand the safety notice, know the correct operation, and receive strict training.

- 操作员应熟悉本产品的结构和工作原理。
- The operator should be familiar with the structure and working principle of this product.
- 操作员必须熟悉相关的国家和地区标准。
- Operators must be familiar with relevant national and regional standards.

2.3. 运行环境要求 Operating Environment Requirements

操作环境可能会影响设备的使用寿命和可靠性。因此，请避免在以下环境中使用设备：

The operating environment may affect the service life and reliability of the equipment. Therefore, please avoid using the device in the following environments:

- 温度和湿度超过技术规范的地方（温度：-20℃~+55℃；相对湿度：0%~95%）。
- Places where the temperature and humidity exceed the technical specifications (temperature: -20 °C~+55 °C; relative humidity: 0%~95%).
- 有振动或冲击的地方。
- Places with vibration or impact.
- 有灰尘、腐蚀性物质、盐或可燃气体的地方。
- Places with dust, corrosive substances, salt, or flammable gases.
- 通风不良或封闭的地方。
- Poor ventilation or enclosed areas.

3. 产品说明 Product Introduction

本章主要介绍产品特点、外观及操作面板、工作原理、操作模式等。

This chapter mainly introduces the product features, appearance and operation panel, working principle, operation mode, etc.

3.1. 产品简介 Product Overview

3.1.1. 产品型号 Product Model

产品型号为：OLP-EIB-V541_E111_P50-A001

<p>OLP 50kW/111kWh 风冷光储一体柜用户手册 OLP 50kW/111kWh Air Cooling Energy Storage Cabinet All-In-One Product User Manual</p>	<p>文件编号： OLP-EIB-V541_E111_P50-A001-1001 Document number: OLP-EIB-V541_E111_P50-A001-1001</p>	<p>版本：V0.1 Version:V0.1</p>	<p>Page 11 of 97</p>
<p>© 欧力普能源与自动化技术有限公司 2024 保留所有权利 © Olipower Energy & Automation Technologies 2024 All rights reserved.</p>	<p>地址：深圳市光明区凤凰街道塘尾社区光明大道 380 号尚智科技园 2 栋 A 座 10 楼 Address: 10th Floor, Block A, Building 2, Shangzhi Science and Technology Park, No. 380 Guangming Avenue, Tangwei Community, Fenghuang Street, Guangming District, Shenzhen, China.</p>		<p>Tel: +86 (755) 2650 8686 E-mail: sales@olipower.cn</p>

3.1.2. 产品铭牌 Product Nameplate



图 3.1.2 产品铭牌

Figure 3.1.2-1 Product Nameplate

3.1.3.产品规格 Product Specifications

项目 Item		规格参数 Specification
电芯参数 Cell Parameters	额定电压 Rated Voltage (V)	3.22
	额定电量 Rated Energy (Ah)	206
	电芯类型 Cell Type	磷酸铁锂 LFP
	循环次数 Cycles	>6000 (25°C, 0.5C charge/0.5C discharge, 90%DOD, 80%SOH)
电池包参数 Battery PACK Parameters	额定电压 Rated Voltage (V)	77.28
	额定电量 Rated Energy (kWh)	15.9
	电芯成组方式 Cell Configuration	1P24S
	尺寸 Dimension (W*H*D)mm	464*230*880
	冷却方式 Cooling Method	风冷 Air-cooled
	重量 Weight (kg)	130
	防护等级 IP Rating	IP20
电池柜参数 Battery Cabinet Parameters	额定电压 Rated Voltage (V)	540.96
	电压范围 Voltage Range(V)	470.4~604.8
	簇成组方式 Cluster Configuration	1P24S-7S
	额定充/放电电流 Rated Charge/Discharge Current (A)	103
	最大充/放电电流 Max. Charge/Discharge Current (A)	200
	额定电量 Rated Energy (kWh)	111
	高压箱电压 HV BOX Voltage (V)	1000
	热管理方式 Thermal Management	风冷空调 Air conditioner
	消防系统 Fire Supression System	温感+烟感+气溶胶 Heat Detector+Smoke

OLP 50kW/111kWh Air Cooling Energy Storage Cabinet All-In-One

		Detector+Aerosol
	机柜防护等级 Cabinet IP Rating	IP54
	机柜防腐等级 Cabinet Corrosion Protection Level	C3
	工作温度 Working Temperature (°C)	-20~+55
	存储温度 Storage Temperature (°C)	-20~+45
	湿度 Humidity	0~95%RH(无凝露, No condensation)
	海拔高度 Latitude(m)	≤3000
	重量 Weight	1300kg
光伏输入参数 PV Input Specification	最大输入功率 Max. Input Power (kW)	75
	启动电压 Start-up Voltage (V)	135
	额定直流输入电压 Rated DC Input Voltage (V)	620
	MPPT 工作电压范围 MPPT Voltage Range (V)	200-950
	MPPT 数量 No. of MPP Trackers	4
	单路 MPPT 输入路数 No. of DC Inputs per MPPT	2
	最大输入电流 Max. Input Current (A)	30×4
	最大短路电流 Max. Short-circuit Current (A)	40×4
电网端交流输出参数 Grid Side AC Output Specification	额定输出功率 Rated Output Power (kW)	50
	最大并网输出视在功率 Max. Output Apparent Power (kVA)	55
	电池最大充电功率 Max. Charging Power of Batter (kW)	50
	额定电压 Rated AC Voltage (V)	3L/N/PE; 220/380V; 230/400V; 240/415V

OLP 50kW/111kWh Air Cooling Energy Storage Cabinet All-In-One

	电网电压频率 Rated AC Frequency (Hz)	50/60
	最大输出电流 Max. Output Current (A)	83
	功率因数 Power Factor	0.8leading—0.8lagging
	最大总谐波失真 Max. Total Harmonic Distortion	<3% @ 额定功率 Rated Power
	直流分量 DCI	<0.5%In
离网端交流输出参数 Back-up Side AC Output Specification	额定输出功率 Rated Output Power (kW)	50
	最大输出视在功率 Max. Output Apparent Power (kVA)	55
	最大输出电流 Max. Output Current (A)	83
	UPS 切换时间 UPS Switching Time	<20ms
	额定输出电压 Rated Output Voltage (V)	3/N/PE; 220/380V; 230/400V; 240/415V
	额定交流频率 Rated Output Frequency (Hz)	50/60
	电压总谐波失真 Voltage Harmonic Distortion	<3% @ 线性负载 Linear load
效率参数 Efficiency	最大转换效率 Max. Efficiency	98.8%
	欧洲效率 European Efficiency	98.3%
光储混合逆变器保护功能 Hybrid Inverter Protection	直流反极性保护 DC Reverse Polarity Protection	集成 Integrated
	电池输入反接保护 Battery Input Reverse Connection Protection	
	绝缘阻抗反接保护 Insulation Resistance Protection	

	浪涌保护 Surge Protection	
	过温保护 Over-temperature Protection	
	漏电流保护 Residual Current Protection	
	防孤岛保护 Islanding Protection	
	交流过压保护 AC Over-voltage Protection	
	过载保护 Overload Protection	
	短路保护 AC Short-circuit Protection	
光储混合逆变器常规参数 Hybrid Inverter Comment Specification	防护等级 IP Rating	IP65
	待机损耗 Standby Self-consumption (W)	<15
	冷却方式 Cooling Method	智能风扇 Smart Fan
	噪音指数 Noise Level (dB)	<50
	显示 Display	OLED & LED
	通讯 Communication	CAN, RS485, WiFi/4G (Optional)

表 3.1.3 规格参数

Table 3.1.3 Specification Parameters

3.1.4.操作模式 Operation Modes

混合逆变器具有以下基本运行模式，您可以在应用程序中根据自己的偏好配置运行模式。

Hybrid inverter has the following basic operation modes and you can configure the operation mode as per your preference in the App.

常规模式 General Mode	
<p>在这种工作模式下，当光伏阵列的电力充足时，光伏电力将按先负载、再电池、最后电网的顺序为负载、电池和电网供电。</p> <p>In this working mode, when the power from the PV array is sufficient, PV power will supply the loads, battery, and grid in the order of loads first, battery second, and grid last.</p> <p>（当当地电网不允许逆变器向电网馈电时，您可以将向电网输出的功率设置为 0 瓦）。</p> <p>(You can set the power to the grid to 0W when the local grid doesn't allow inverter power to feed to the grid).</p>	
<p>当光伏电力不足时，电池将进行放电以向负载供电；如果电池电量不足以供应负载，则电网将参与供电。</p> <p>When the PV power is insufficient, the battery will discharge to supply loads, and the grid will join in if the battery is not enough to supply loads.</p>	
高峰负荷转移（负荷转移） Peak load Shifting (Load Shifting)	
<p>设置与电网签订合同的最大功率 P_{max}（千伏安）。</p> <p>Set the maximum power P_{max} (kVA) contracted with the grid.</p> <p>当负载消耗功率小于 P_{max} 时，光伏将首先给电池充电，由电网为负载供电。当电池充满电后，光伏将与电网一起为负载供电，但电池不参与供电。</p> <p>When the load consumption is less than the P_{max}, the PV will charge the battery first, and the grid supplies the load. When the battery is full, PV will supply the load together with the grid, but the battery</p>	

doesn't.	
<p>当负载消耗功率超过最大功率 P_{max} 时，逆变器将从电池和光伏获取电力来为负载供电，以补偿超过 P_{max} 的那部分功率。</p> <p>When the load consumption exceeds the P_{max}, the inverter will take power from the battery and PV to supply power to the load to compensate for the power that exceeds the P_{max}.</p>	
<p>要实现“高峰负荷转移”功能，超过最大功率 P_{max} 的负载功率必须在逆变器的最大输出功率范围内，否则，逆变器将仅输出其允许的最大功率。</p> <p>*To realize the “Peak load Shifting” function, the load power that exceeded P_{max} has to be within the inverter max output power, otherwise, the inverter will only output the max power which allowed.</p>	
不间断电源模式 UPS Mode	
<p>在这种工作模式下，逆变器将利用来自光伏或电网的电力为电池充电，直至电池充满电。并且只要电网正常供电，电池就不会进行放电。</p> <p>In this working mode, the inverter will use the power from PV or grid to charge the battery until it is fully charged, and as long as the grid is there, the battery won't discharge.</p>	
<p>当电网停电时，来自光伏和电池的电力将为连接在备用侧（不间断电源）的负载供电。</p> <p>When the grid fails, power from PV and battery will supply loads connected on the back-up side (UPS).</p>	
经济模式 Economic Mode	

<p>在这种工作模式下，您可以在应用程序中设置充/放电功率和时间，逆变器将在预定时间段内利用来自光伏或电网的电力（是否使用电网电力可在应用程序中设置）为电池充电。</p> <p>In this working mode, you can set charge/discharge power and time in the App, inverter will use the power from PV or grid (whether to use can be set in the App) to charge the battery in the predetermined period.</p>	
<p>在预定时间段内，逆变器将利用来自光伏和电池的电力为负载供电，电力不足的部分将由电网提供。</p> <p>Inverter will use power from PV and battery to supply loads in the predetermined period and the insufficient part will be supplied by the grid.</p>	
离网模式 Off-grid Mode	
<p>在纯离网模式下，光伏产生的电力将首先为备用负载供电，若有剩余电力，则会给电池充电。</p> <p>In the purely off-grid mode, power from PV will supply the back-up loads first and then charge the battery if there's surplus power.</p>	
<p>当光伏产生的电力不足时，电池将进行放电，与光伏一起为备用负载供电。</p> <p>When the power from PV isn't enough, the battery will discharge to supply back-up loads together with PV.</p>	

表 3.4.1 操作模式

Table 3.4.1 3.4.1 Operating Mode

3.2. 系统原理图 System Schematic Diagram



图 3.2 系统原理图

Figure 3.2 System Schematic Diagram

3.3. 外观尺寸 Appearance Dimensions

3.3.1. 外观 Appearance

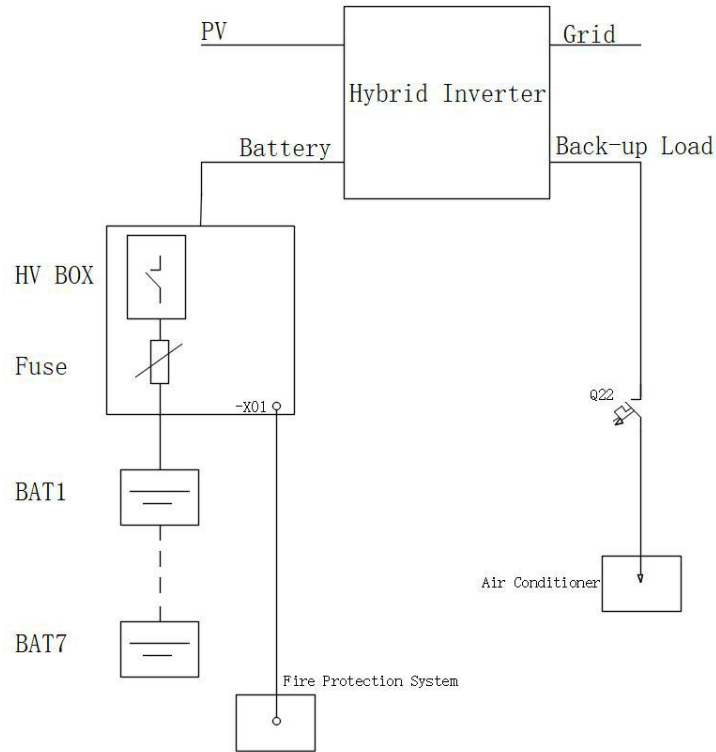

图 3.3.1 外观

Figure 3.3.1 Appearance

3.3.2.尺寸 Dimension



图 3.3.2 柜体尺寸 (单位: mm)
Figure 3.3.2 Cabinet size (unit: mm)

3.3.3.显示面板 Display Panel

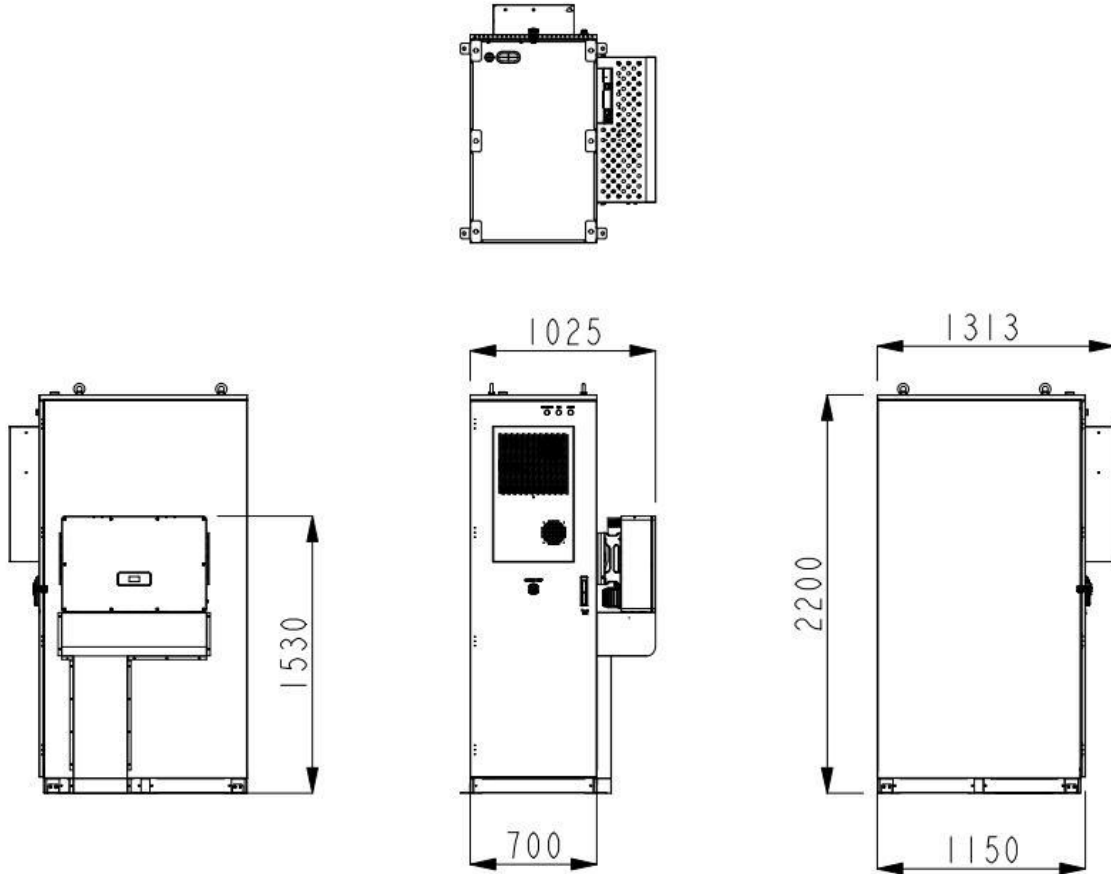

图 3.3.3 显示面板
Figure 3.3.3 Display panel

序号 NO.	丝印 Definition	说明 Explain
1	AUX POWER	系统控制电源上电后，绿色电源指示灯常亮 After the system control power is turned on, the green power indicator light remains on
2	RUN	系统功率输出或者输入时，黄色运行指示灯常亮 When the system power is output or input, the yellow running indicator light is always on
3	ALARM	系统故障时，红色故障指示灯常亮 When the system malfunctions, the red fault indicator light remains on

表 3.3.3 显示面板说明

Table 3.3.3 Display Panel Description

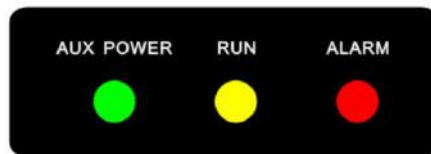
3.4. 部件说明 Component Description



图 3.4 部件说明图示

Figure 3.4 Component Description Diagram

OLP 50kW/111kWh Air Cooling Energy Storage Cabinet All-In-One

序号 No.	名称 Name	说明 Description
1	网络系统 Network System	系统配备 4G 天线+4G 路由器+WIFI 模块，支持云端数据监控平台(选配功能)。 The system is equipped with a 4G antenna +4G router +WIFI module, and supports a cloud data monitoring platform (optional function).
2	门禁系统 Access Control System	系统配备门禁开关，负责监控柜门情况。 The system is equipped with access control switches, which are responsible for monitoring the status of the cabinet doors.
3	热管理系统 Thermal Management System	系统配备储能专用空调，支持制冷和制热功能 The system is equipped with a dedicated air conditioner for energy storage, supporting both cooling and heating functions.
4	电池箱 Battery Pack	系统配备 7 个风冷电池箱，含 BSU，监控电池数据。 The system is equipped with 7 air-cooled battery packs, including BSU, to monitor battery data.
5	高压控制箱 HV Control Box	系统配备 1 个高压控制箱，含 BMU，负责电池簇的监控和保护。 The system is equipped with one high-voltage control box, including BMU, which is responsible for the monitoring and protection of the battery cluster.
6	消防系统 Fire Protection System	配置气溶胶自动灭火系统，并预留水消防接口，为储能系统提供柜消防保护能力。 Configure an aerosol automatic fire extinguishing system and reserve water fire protection interfaces to provide cabinet fire protection capabilities for the energy storage system.
7	指示灯 Indicator Light	指示系统的上电、运行、故障状态。 Indicate the power-on, operation and fault status of the system.
8	急停按钮 Emergency Stop Button	设备异常状态或者紧急情况时，按下急停按钮，系统停止工作。 When the equipment is in an abnormal state or in an emergency, press the emergency stop button and the system will stop working.
9	混合逆变器 Hybrid Inverter	外挂式高压混合逆变器，实现并网、离网、光伏、柴油机等储能应用。 External high-voltage hybrid inverters are used to achieve grid-connected, off-grid, photovoltaic, diesel engine and

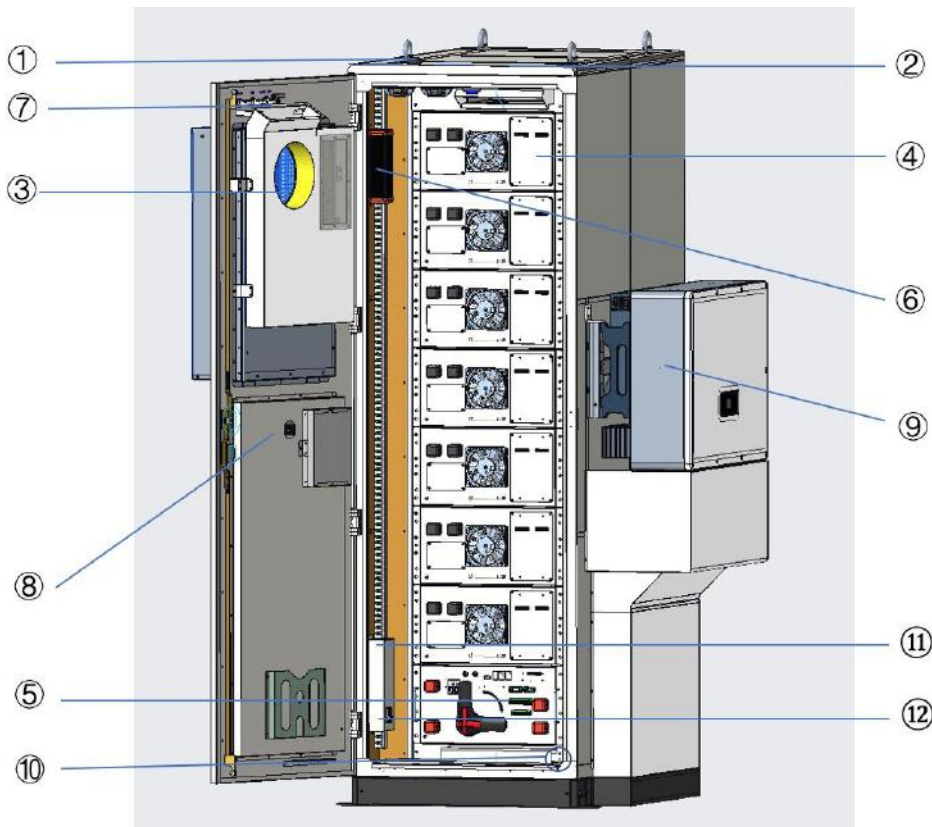
		other energy storage applications.
10	水浸报警系统 Water Immersion Alarm System	提供有效的漏水监测手段，有助于及时发现并处理漏水问题，保障储能柜的安全运行。 Providing effective leakage monitoring means, helps to detect and deal with leakage problems in time, ensures the safe operation of the cabinet.
11	空调断路器 Air Conditioning Circuit Breaker	负责管理空调交流供电。 Be responsible for managing the AC power supply of air conditioners.
12	端子排 Terminal Block	

表 3.4 部件说明表

Table 3.4 Component Description Table

3.4.1. 储能系统 Energy Storage System

➤ 风冷电池包 Air-cooled Battery Pack

电池箱内部包含电芯,BSU（电池数据采集单元），温度传感器以及液冷底盘，BSU 采集电芯的数据上传置电池管理系统。

The battery box contains battery cells, BSU (Battery Data Acquisition Unit), temperature sensors, and liquid cooled chassis. The BSU collects data from the battery cells and uploads it to the battery management system.



图 3.4.1-1 电池包外型图

图 3.4.1-1 Appearance of Battery Pack

➤ 电池箱参数表 Battery pack parameter list:

序号 No.	项目 Item	规格/参数 Specifications/P arameters	备注 Note
1	标称电压 (V) Nominal Voltage (V)	77.28	

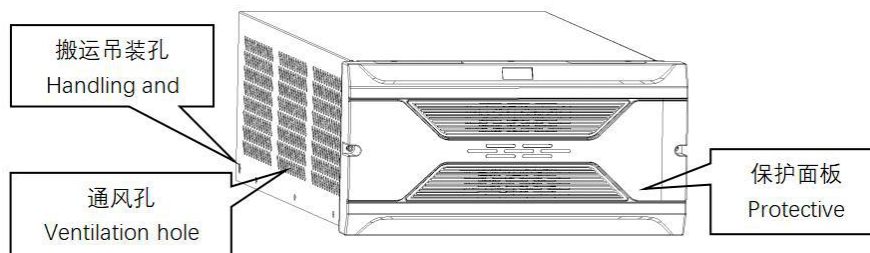
OLP 50kW/111kWh Air Cooling Energy Storage Cabinet All-In-One

2	工作电压范围 (V) Working Temperature Range (V)	67.2~86.4	
3	额定容量 (Ah) Rated Capacity (Ah)	≥206.0	25±2℃, 0.5C, 2.5-3.65V
4	额定电量 (KWh) Rated Energy (kWh)	≥15.9	25±2℃, 0.5C, 2.5-3.65V
5	交流内阻 (mΩ) AC Resistance (mΩ)	≤12.0	新电池状态, 1KHz New battery status, at 1KHz
6	成组方式 Configuration	1P24S	
7	绝缘值 (MΩ) Insulation Value (MΩ)	≥300	设置测试电压 1000V, 测试阻值 > 300MΩ 则判定为正常 Set the test voltage 1000V, the test resistance value > 300MΩ is judged as normal.
8	耐压值 Withstanding voltage value	3300V, 1mA	设置测试电压 3300VDC, 爬升时间 0.1S, 测试时间 3S, 漏电流 < 1mA 则判定为正常 Set the test voltage 3300VDC, climb time 0.1S, test time 3S, leakage current < 1mA is judged as normal.
9	重量 (Kg) Weight (Kg)	~130Kg	
10	尺寸 (W*H*D) (mm) Dimension (W*H*D) (mm)	464*230*880mm	
11	标准充放电 (A) Standard charge/discharge (A)	103/103	25±2℃
12	最大持续充/放电倍率 Maximum continuous charge/discharge ratio	1P/1P	25±2℃/20-45℃
13	充电温度范围 (℃) Charging temperature range	0~55	
14	放电温度范围 (℃) Discharging temperature	-20~55	

	range		
15	湿度 (%) Humidity (%)	0~95	无凝露 No condensation
16	模组冷却方式 Module Cooling Method	Forced air-cooled	
17	模组加热方式 Module heating method	None	
18	出货时荷电量 (SOC) Charge on shipment	30±5%	
19	模组自放电率 Module self-discharge rate	≤3% / month	新出货电芯, 25±2°C, 30% 存储 3 个月内 New shipped cells, 25±2°C, 30% storage within 3 months
20	循环寿命 Cycle life	≥6000	0.5C, 90%DOD, 80%SOH
21	防护等级 Levels of protection	IP20	
22	海拔高度 (m) Altitude (m)	≤3000	
23	储存温度范围 (°C) Storage temperature range (°C)	-20~45	
24	防腐蚀等级 Anti-corrosion grade	C3	
25	使用寿命 Life length	10 years or 6000 cycles	以先到为准 Whichever condition comes first
26	认证 Attestation	EC62619 IEC62040 IEC61000 UN38.3 MSDS	

表 3.4.1-2 电池箱参数表

表 3.4.1-2 Battery Pack function Parameters

- 接口定义
- Interface definition



图 3.4.1-3 电池箱接口面板

Figure 3.4.1-3 Battery pack panel interface

序号 No.	项目 Item	内容 Identification	注意 Note
A	正极 Positive Pole	B+	
B	负极 Negative Pole	B-	
C	风扇 Fan		
D	供电及通讯输入 Power Supply and Communication Input	COM IN	
E	供电及通讯输出 Power Supply and Communication Output	COM OUT	
F	电池箱供电口 Pack Fixing Holes		
G	手柄 Handle		
H	接地螺栓 Grounding Bolt Hole		

表 3.4.1-4 电池 Pack 接口功能表

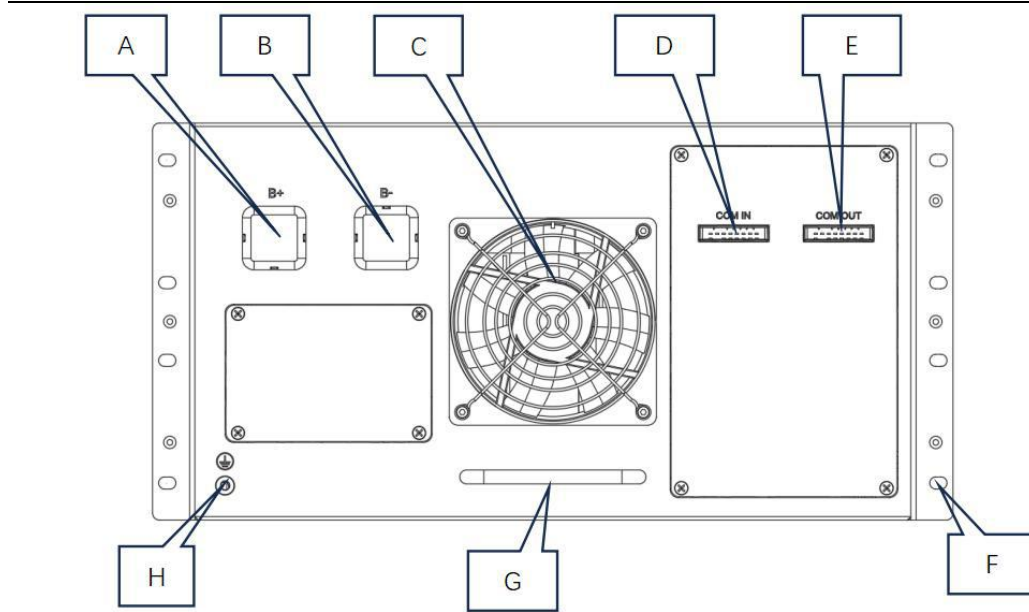
Table 3.4.1-4 Description of battery pack panel interface

OLP 50kW/111kWh 风冷光储一体柜用户手册 OLP 50kW/111kWh Air Cooling Energy Storage Cabinet All-In-One Product User Manual	文件编号: OLP-EIB-V541_E111_P50-AO01-1001 Document number: OLP-EIB-V541_E111_P50-AO01-1001	版本: V0.1 Version: V0.1	Page 28 of 97
© 欧力普能源与自动化技术有限公司 2024 保留所有权利 © Olipower Energy & Automation Technologies 2024 All rights reserved.	地址: 深圳市光明区凤凰街道塘尾社区光明大道 380 号尚智科技园 2 栋 A 座 10 楼 Address: 10th Floor, Block A, Building 2, Shangzhi Science and Technology Park, No. 380 Guangming Avenue, Tangwei Community, Fenghuang Street, Guangming District, Shenzhen, China.		Tel: +86 (755) 2650 8686 E-mail: sales@olipower.cn

OLP 50kW/111kWh Air Cooling Energy Storage Cabinet All-In-One

➤ 高压控制箱 High voltage control box

高压控制箱内部包 BMU（电池管理单元）高压接触器，高压熔断器，电流互感器等。用于控制直流回路的闭合和切断。实现直流侧电压，温度，电流的各级保护。

The high-voltage control box contains BMU (Battery Management Unit) high-voltage contactors, high-voltage fuses, current transformers, etc. Used to control the closure and disconnection of DC circuits. Realize various levels of protection for DC side voltage, temperature, and current.



图 3.4.1-5 高压控制箱外形图

图 3.4.1-5 Appearance of High Voltage Control Box

➤ 高压箱参数表 HV box parameter list:

序号 No.	项目 Item	规格/参数 Specifications/Parameters
1	主回路最高工作电压 Maximum working voltage of main circuit	DC 1000V
2	交流供电 AC power supply	AC230V 50Hz 10A
3	额定充电/放电电流 Rated charge/discharge current	103A/103A
4	最大充/放电电流 Maximum charge/discharge current	200A/200A
5	主动保护 Active protection	250A 接触器 250A contactor

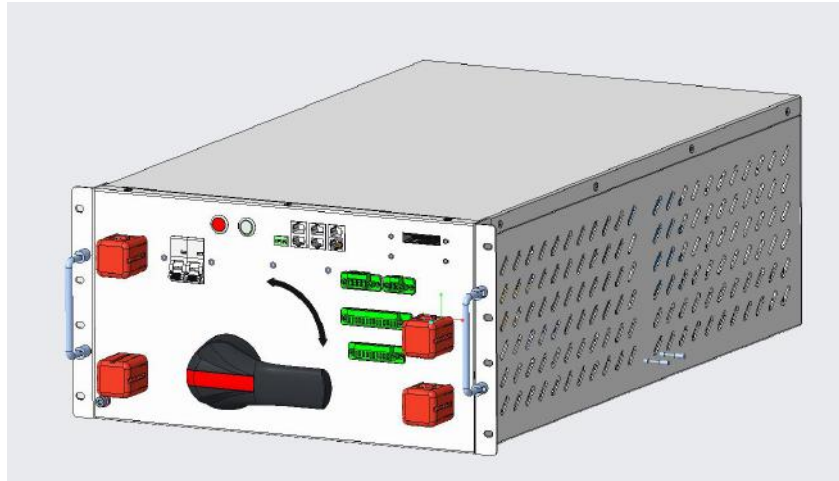
6	被动保护 Passive protection	315A/1500Vdc 熔断器 315A/1500Vdc Fuse
7	手动断路器 Manual circuit breaker	250A/1500Vdc 隔离开关 250A/1500Vdc Isolation switch
8	常规工作温度 General operating temperature	25° C
9	存储温度范围 Storage temperature range	-20° C to +45° C
10	串联单元 Series unit	4~11 个电池模组串联 4~11 Battery modules in series
11	对外通讯接口 External communications interface	CAN3/RS485-1
12	并联通讯接口 Parallel communication interface	CAN2
13	内部通讯接口 Internal communication interface	CAN1
14	维护监控接口 Maintenance monitoring interface	RS232
15	热管理通讯接口	RS485-2
16	尺寸 (宽*高*厚) Dimensions (W*H*T)	464*230*720mm
17	重量 Weight	~30kg
18	防护等级 IP class	IP20

表 3.4.1-6 电池箱参数表

表 3.4.1-6 High Voltage Control Box function Parameters

- 接口定义
- Interface definition



图 3.4.1.4-7 高压箱协议接口

Figure 3.4.1-7 High Voltage Control Box interface

序号 No.	项目 Item	描述 Identification	备注 Note
A	电池正极 Battery Positive Pole	B+	红色 Red
B	电池负极 Battery Negative Pole	B-	黑色 Black
C	故障灯 Fault Indicator Light	报警 ALM	红色 Red
D	运行灯 Operation Indicator	运行 RUN	绿色 Green
E	接口板 Interface Board		
F	PACK 智能风扇 Pack Fan Control Terminal		
G	PACK 通信接口 Pack Communication Interface		
H	电池簇固定接口 Rack Fixing Hole		
I	逆变器正极 Inverter Positive Pole	P+	红色 Red

J	逆变器负极 Inverter Negative Pole	P-	黑色 Black
K	输出端子 DO Terminal Block		
L	输入端子 DI Terminal Block		
M	隔离开关 Disconnecter Switch		
N	接地端子 Grounding Terminal		
O	手柄 Handle		

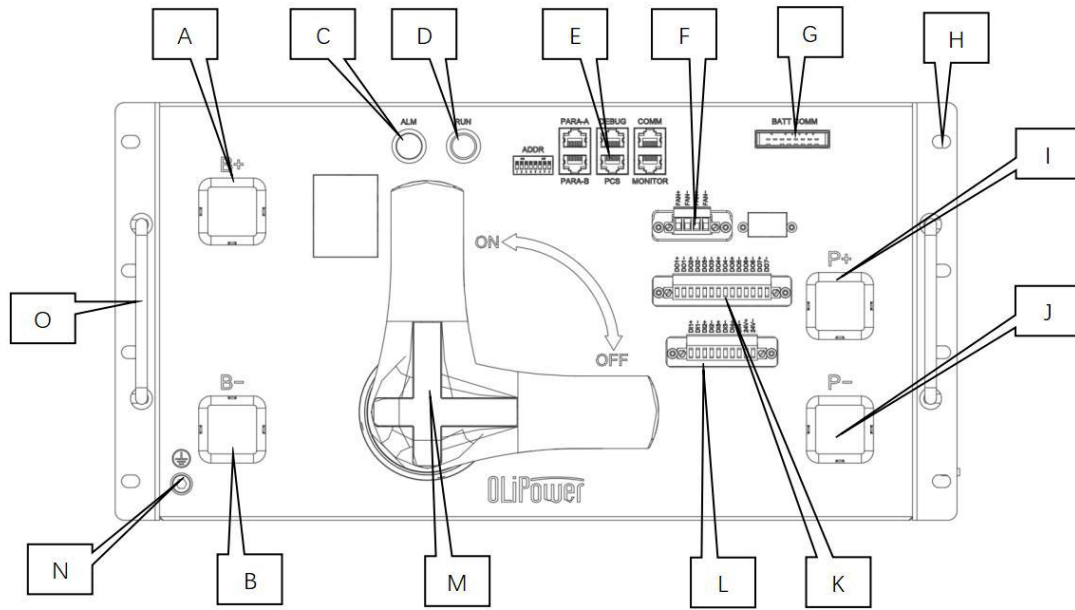
表 3.4.1-8 高压箱接口协议描述

Table 3.4.1-8 Description of High Voltage Control Box interface

➤ 电池簇 Battery cluster

电池簇内部配备电池箱与高压控制箱。动力回路采用动力线缆串联，通讯回路采用带屏蔽的多芯线连接。

The battery cluster is equipped with a battery module and a high-voltage control box inside. The power circuit is connected in series with power cables, and the communication circuit is connected with shielded multi-core wires.

	配置 configure	1P168S
	标称能量 nominal energy	111kWh
	工作电压范围 Operating Voltage Range	470.4~604.8Vdc
	最大充放电电流 Maximum charge/discharge current	200A
	尺寸(宽*高*深)mm Dimension (W*H*D) mm	464*1900*880mm
	重量 weights	≈900kg
	认证 accreditation	/

表 3.4.1-9 电池簇技术参数

Table 3.4.1-9 Technical Parameters of Battery Clusters

OLP 50kW/111kWh 风冷光储一体柜用户手册 OLP 50kW/111kWh Air Cooling Energy Storage Cabinet All-In-One Product User Manual © 欧力普能源与自动化技术有限公司 2024 保留所有权利 © Olipower Energy & Automation Technologies 2024 All rights reserved.	文件编号: OLP-EIB-V541_E111_P50-AO01-1001 Document number: OLP-EIB-V541_E111_P50-AO01-1001	版本: V0.1 Version:V0.1	Page 32 of 97 Tel: +86 (755) 2650 8686 E-mail: sales@olipower.cn
---	---	--------------------------	---

地址: 深圳市光明区凤凰街道塘尾社区光明大道 380 号尚智科技园 2 栋 A 座 10 楼
 Address: 10th Floor, Block A, Building 2, Shangzhi Science and Technology Park, No. 380 Guangming Avenue, Tangwei Community, Fenghuang Street, Guangming District, Shenzhen, China.

电池管理系统 Battery Management System

电池管理系统分为 2 个级别：BMU 和 BSU。

Battery management systems are categorized into 2 levels: BMU and BSU.

- BSU 安装在电池箱，负责采集电池箱内电池单体数据，并上传。
- The BSU is installed in the battery box and is responsible for collecting data from the battery cells in the battery box and uploading it.
- BMU 安装在高压控制箱，负责接收并处理 BSU 上传的电池单体电压和温度数据，电流互感器数据，以及 SOC 计算和校正，执行电流，电压，温度等各级逻辑保护。
- The BMU is installed in the high-voltage control box and is responsible for receiving and processing the battery cell voltage and temperature data uploaded by the BSU, the current transformer data, as well as SOC calculations and corrections, and executing all levels of logic protection such as current, voltage, and temperature.



图 3.4.1-10 管理系统拓扑图

图 3.4.1-10 Management System Topology

序号 NO.	项目 Project	参数 Parameter
1	工作电压 Supply voltage	BMU&BSU: 24Vdc
2	单体电压采样精度 Individual voltage sampling accuracy	±5mV (0℃~60℃)
3	总电压采样精度	1%FSR

	Total voltage sampling accuracy	
4	总电压采样范围 Total voltage sampling range	0~1500Vdc
5	电流采样精度 Current sampling accuracy	1%RDG
6	电流采样范围 Current sampling range	-200~+200A
7	温度采样精度 Temperature sampling accuracy	±2℃ (-10℃~+50℃)
8	SOC 准确度 SOC accuracy	≤5%，系统每月需要完全充满 1 次 The system needs to be fully charged once a month

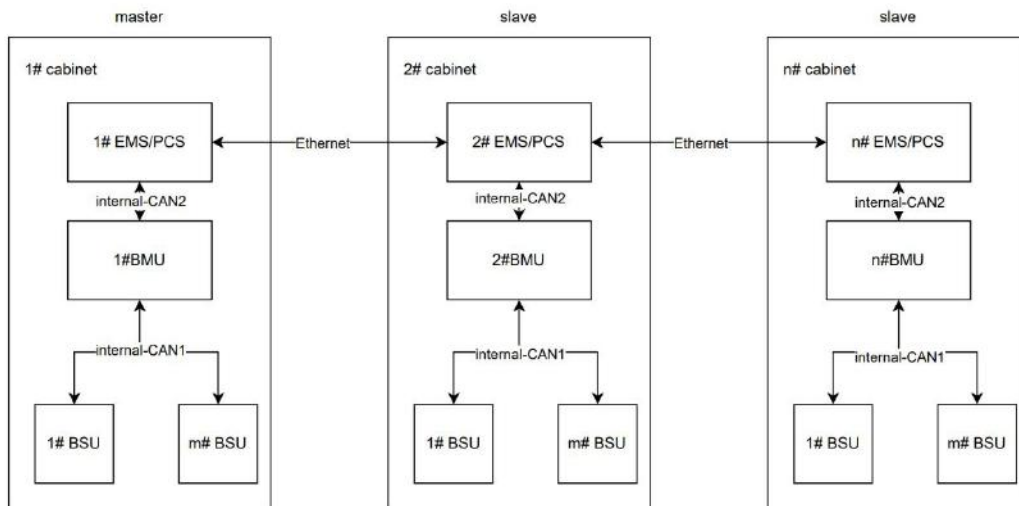
表 3.4.1-10 电池管理单元

Table 3.4.1-10 Battery Management Unit



图 3.4.1-8 电池管理单元拓扑图

Figure 3.4.1-8 Topology diagram of battery management unit

3.4.2. 热管理系统 Thermal Management System

空调 Air conditioners

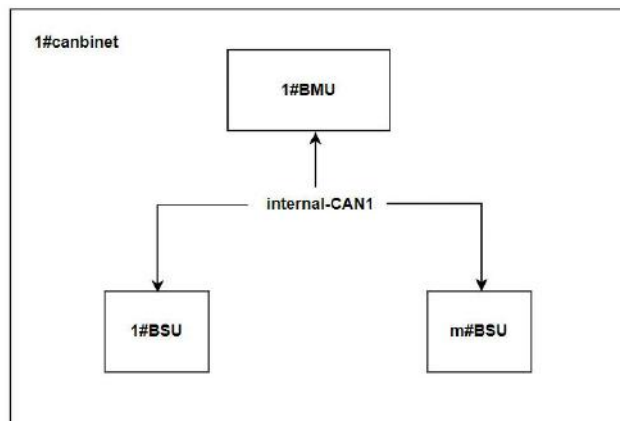
- 空调主要由压缩机、风机、冷凝器、蒸发器、电加热、主控板以及其他配件构成。
- Air conditioner is mainly made up of compressors, fans, condensers, evaporators,

electric heating, main control boards, and other accessories.

- 空调用于调节储能系统内环境温度，确保电池组在合适温度范围内工作，以维持系统的最佳工作状态和提高系统使用寿命，其功能如下：
- The air conditioner is used to regulate the ambient temperature within the energy storage system to ensure that the battery pack operates within the appropriate temperature range to maintain the optimal working condition of the system and to improve the service life of the system, and its functions are as follows:
- 监控电池仓内环境温度，根据环境温度和电池组内部温度自动调节温度输出。
- Monitor the ambient temperature inside the battery compartment and automatically adjust the temperature output according to the ambient temperature and the internal temperature of the battery pack.
- 电池仓温度较高时，空调降低电池仓环境温度，防止热失控事故。
- When the temperature of the battery compartment is high, the air conditioner reduces the ambient temperature of the battery compartment to prevent thermal runaway accidents.
- 电池仓温度较低时，空调可进行预热，提高环境温度，确保系统在低温环境下充放电性能与安全性，同时提高系统的使用效率。
- When the temperature of the battery compartment is low, the air conditioner can preheat and raise the ambient temperature to ensure the system's charging and discharging performance and safety in a low-temperature environment, as well as to improve the system's utilization efficiency.

制冷模式 cooling mode

制冷时，压缩机将制冷剂压缩成液体，而此时将液体送入电池仓内，此时电池仓内热空气和蒸发器接触，液体制冷剂受热变气态，带走电池仓内热量，到冷凝器，在风机吹动及压力变化下，快速放热到电池仓外。

Refrigeration, the compressor will compress the refrigerant into liquid, and at this time the liquid will be sent to the battery compartment, at this time the hot air in the battery compartment and the evaporator contact, the liquid refrigerant is heated into a gaseous state, take away the heat in the battery compartment, to the condenser, in the fan blowing and the pressure change, the rapid exothermic to the outside of the battery compartment.

制热模式 heating mode

制热时，风机与电加热启动，将经过热风吹动至电池仓内，达到制热效果。

When heating, the fan and electric heating are activated to blow the passing hot air into the battery compartment to achieve the heating effect.

项目	参数
----	----

OLP 50kW/111kWh 风冷光储一体柜用户手册 OLP 50kW/111kWh Air Cooling Energy Storage Cabinet All-In-One Product User Manual	文件编号： OLP-EIB-V541_E111_P50-AO01-1001 Document number: OLP-EIB-V541_E111_P50-AO01-1001	版本: V0.1 Version:V0.1	Page 35 of 97
--	---	--------------------------	---------------

Item	Parameters
额定制冷量 Rated Cooling Capacity	1500W (50Hz)
额定制冷功率 Rated Cooling Power	580W (50Hz)
制热量 Heating capacity	1000W
工作环境温度 Working environment temperature	-40°C~+55°C
噪音 Noise	60dB (A)
电源 Power supply	工作电压范围: 220±15%, 50/60Hz; 额定/最大电流: 4.6A Operating voltage range: 220±15%, 50/60Hz; rated/maximum current: 4.6A
防护等级 IP class	IP55
通讯方式 Communication method	RS485
工作温度范围 Working Temperature	20°C~50°C
重量 Weight	24kg
尺寸 Size	446*200*746mm

表 3.4.2 空调技术参数表

Table 3.4.2 Air conditioner technical parameters table

3.4.3. 消防系统 Fire Protection System

消防系统由温度感应器，烟雾感应器，以及气溶胶灭火装置组成。

The fire protection system consists of temperature sensors, smoke sensors, and aerosol fire extinguishing devices.

消防警报：温度感应器贺烟雾感应器同时触发，BMS 发出警报并切断主回路。

Fire alarm: The temperature sensor and smoke sensor are triggered simultaneously, and the BMS issues an alarm and cuts off the main circuit.

OLP 50kW/111kWh 风冷光储一体柜用户手册 OLP 50kW/111kWh Air Cooling Energy Storage Cabinet All-In-One Product User Manual	文件编号: OLP-EIB-V541_E111_P50-AO01-1001 Document number: OLP-EIB-V541_E111_P50-AO01-1001	版本: V0.1 Version: V0.1	Page 36 of 97
© 欧力普能源与自动化技术有限公司 2024 保留所有权利 © Olipower Energy & Automation Technologies 2024 All rights reserved.	地址: 深圳市光明区凤凰街道塘尾社区光明大道 380 号尚智科技园 2 栋 A 座 10 楼 Address: 10th Floor, Block A, Building 2, Shangzhi Science and Technology Park, No. 380 Guangming Avenue, Tangwei Community, Fenghuang Street, Guangming District, Shenzhen, China.		Tel: +86 (755) 2650 8686 E-mail: sales@olipower.cn



图 3.4.3 消防系统拓扑图

Figure 3.4.3 Topology diagram of fire protection system

3.4.4. 门禁系统 Access Control System

系统配备门禁系统，每扇柜门都有门禁开关监控，保证柜体安全。任意一扇柜门被打开后，门禁系统将状态上报 BMS，BMS 显示门禁警报。（注意：门禁报警只显示报警状态，不影响系统运行）

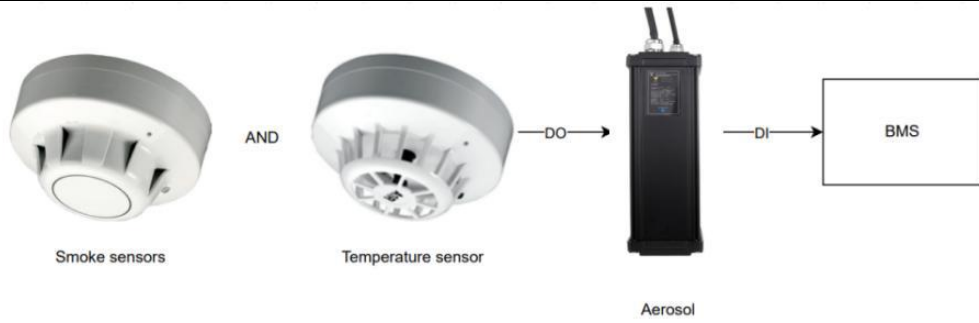
The system is equipped with an access control system, and each cabinet door is monitored by an access control switch to ensure the safety of the cabinet. After any cabinet door is opened, the access control system will report the status to the BMS, and the BMS will display an access control alarm. (Note: The access control alarm only displays the alarm status and does not affect the system operation)

3.4.5. 水浸系统 Flood Protection System

水浸系统是由水浸变送器和水浸传感器组成。

The flood system is composed of a flood transmitter and a flood sensor.

3.4.6. 混合逆变器 Hybrid Inverter

系统配备储能双向逆变器，具备恒压、恒流、恒功率模式，支持离网、并网运行，可在多种模式之间智能切换，同时具有无功功率补偿及谐波补偿功能，可实现多机并联。

The system is equipped with a bidirectional inverter for energy storage, featuring constant voltage, constant current and constant power modes. It supports both off-grid and grid-connected operation and can intelligently switch between multiple

modes. Additionally, it has reactive power compensation and harmonic compensation functions, enabling parallel connection of multiple units.

➤ 外观 Appearances



➤ 混合逆变器参数表 Hybrid Inverter Datasheet

逆变器参数表

Inverter Parameter Table

类型 typology	项目 sports event	参数 parameters
直流侧 DC side	额定电压 rated voltage	541Vdc
	额定能量 Rated energy	111kWh
	电压范围 voltage range	135~750Vdc
	充/放电功率 Charge/Discharge	55kW
	最大充放电电流 Maximum charge/discharge current	100A
交流并网 alternating current and grid-connected (AC)	最大输入视在功率 Maximum input apparent power	60kVA
	最大输入有功功率 Maximum input active power	50kW
	额定输入电压 Rated Input Voltage	230/400Vac, 3P+N+PE
	最大持续输入电流	83A

	Maximum Continuous Input Current	
	额定输入频率 Rated Input Frequency	50/60Hz
	功率因数 power factor	0.8cap-0.8ind
通信 correspond (by letter etc)	电池 BMS 通信接口 Battery BMS communication interface	CAN、RS485
	监控通信接口 Monitoring Communication Interface	Ethernet、RS485
	监控通信协议 Monitoring Communication Protocols	Modbus TCP/ Modbus RTU

表 3.4.6 逆变器参数表

Figure 3.4.6 Inverter parameter table

4. 安装 Installation

本章介绍储能柜的安装，包括安装前的准备、安装环境、逆变器安装、电气连接等要求。

This chapter introduces the installation of energy storage cabinets, including preparation before installation, installation environment, inverter installation, electrical connection requirements, etc.

4.1. 安装准备 Installation Preparation

4.1.1. 安装工具 Installation Tools

















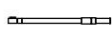





 Clamp meter	 Multi-meter	 Label paper	 Phillips screwdriver
 Flat-head screwdriver	 Socket wrench	 Adjustable wrench	 Torque wrench
 COAX crimping tool	 Diagonal pliers	 Wire stripper	 Claw hammer
 Hammer drill	 Insulation tape	 Cotton cloth	 Brush
 Heat shrink tubing	 Heat gun	 Electrician's knife	 Protective gloves
 ESD gloves	 Insulated gloves	 Hydraulic pliers	 Cable tie

图 4.1.1 安装工具图表

Figure 4.1.1 Installation Tools Table



注意安全 Caution!

安装工具必须绝缘，避免触电。

The installation tools must be insulated to avoid electric shock.

4.1.2. 安装环境 Installation Environment

储能柜的安装环境应满足以下要求：

The installation environment of energy storage cabinets should meet the following requirements:

OLP 50kW/111kWh 风冷光储一体柜用户手册 OLP 50kW/111kWh Air Cooling Energy Storage Cabinet All-In-One Product User Manual	文件编号： OLP-EIB-V541_E111_P50-AO01-1001 Document number: OLP-EIB-V541_E111_P50-AO01-1001	版本：V0.1 Version:V0.1	Page 40 of 97
© 欧力普能源与自动化技术有限公司 2024 保留所有权利 © Olipower Energy & Automation Technologies 2024 All rights reserved.	地址：深圳市光明区凤凰街道塘尾社区光明大道 380 号尚智科技园 2 栋 A 座 10 楼 Address: 10th Floor, Block A, Building 2, Shangzhi Science and Technology Park, No. 380 Guangming Avenue, Tangwei Community, Fenghuang Street, Guangming District, Shenzhen, China.		Tel: +86 (755) 2650 8686 E-mail: sales@olipower.cn

- 储能柜为户外柜，符合 IP54 防护等级，将设备安装在干燥、无灰尘的环境中。
- The energy storage cabinet is an outdoor cabinet that meets the IP54 protection level and is installed in a dry, dust-free environment.
- 场地必须保持良好的通风环境，尽量避免太阳直射，有必要的防火、防水和防鼠、虫处理理。
- The venue must maintain a good ventilation environment, avoid direct sunlight as much as possible, and have necessary fire prevention, waterproofing, and rodent and insect prevention measures.
- 场地应远离有毒有害气体集中的区域，远离易燃、易爆、腐蚀性物品。
- The site should be kept away from areas where toxic and harmful gases are concentrated, as well as from flammable, explosive, and corrosive materials.
- 场地安装面必须平整干燥，严禁有积水，地面必须高于往年积水最高水平面。
- The installation surface of the site must be flat and dry, and there must be no standing water. The ground must be higher than the highest level of standing water in previous years
- 场地地面水平不晃动，并能承载机柜的重量，禁止有凹陷或倾斜。
- The ground level of the venue should not shake and should be able to bear the weight of the cabinet. It is prohibited to have dents or tilts.
- 储能柜前后左右以及上方必须留有足够的空间用于散热、维护和逃生。
- Adequate space must be left in front, back, left, right, and above the energy storage cabinet for heat dissipation, maintenance, and evacuation.
- 避免在阴雨或潮湿的天气条件下，打开柜门、进行安装。
- Avoid opening cabinet doors and installing in rainy or humid weather conditions.
- 温度应在-20℃至+50℃的范围内，以确保储能柜保持良好状态工作。
- The temperature should be within the range of -20 °C to+50 °C to ensure that the energy storage cabinet operates in good.

4.2. 搬运 Handling



注意安全 Caution!

长途搬运注意事项:

Precautions for long-distance transportation:

- 请将产品进行严格包装后再进行车辆运输，长途运输时必须使用封闭的箱体!
- Please strictly package the product before transportation by vehicle. Closed boxes must be used for long-distance transportation!
- 严禁将本产品与可能对本产品构成影响或损害的设备或物品一起混装运输!
- It is strictly prohibited to mix and transport this product with equipment or

<p>OLP 50kW/111kWh 风冷光储一体柜用户手册 OLP 50kW/111kWh Air Cooling Energy Storage Cabinet All-In-One Product User Manual</p>	<p>文件编号: OLP-EIB-V541_E111_P50-AO01-1001 Document number: OLP-EIB-V541_E111_P50-AO01-1001</p>	<p>版本: V0.1 Version:V0.1</p>	<p>Page 41 of 97</p>
<p>© 欧力普能源与自动化技术有限公司 2024 保留所有权利 © Olipower Energy & Automation Technologies 2024 All rights reserved.</p>	<p>地址: 深圳市光明区凤凰街道塘尾社区光明大道 380 号尚智科技园 2 栋 A 座 10 楼 Address: 10th Floor, Block A, Building 2, Shangzhi Science and Technology Park, No. 380 Guangming Avenue, Tangwei Community, Fenghuang Street, Guangming District, Shenzhen, China.</p>		<p>Tel: +86 (755) 2650 8686 E-mail: sales@olipower.cn</p>

items that may affect or damage it!

 **注意安全 Caution!**

叉车搬运注意事项:

Precautions for forklift handling:

- 需使用叉车试叉，若不合适需调整叉车脚位置。试叉合适后又起机柜，再搬运！
- A forklift test fork is required, and if it is not suitable, the forklift foot position needs to be adjusted. After the fork is suitable, lift up the cabinet and then move it!
- 在搬运过程中设备斜角需小于 8°，起伏高度尽量低！
- During the transportation process, the equipment tilt angle should be less than 8 ° and the height of the undulations should be as low as possible!
- 禁止液压车长距离搬运或走斜坡路！
- Do not use hydraulic trucks for long-distance transportation or on sloping roads!
- 起降需轻起轻放，避免冲击或振动叉车，下降时，需要注意不压到脚！
- When taking off and landing, handle with care to avoid impact or vibration of the forklift. When descending, be careful not to press your feet!
- 挪动时，左右需要有人扶持，注意地面平整！
- When moving, someone needs to support you left and right, and pay attention to the flatness of the ground!
- 考虑到设备较高，可能会遮挡驾驶员的视线，建议视情况安排人员对驾驶员进行指引！
- Considering that the equipment is relatively high and may obstruct the driver's line of sight, it is recommended to arrange personnel to guide the driver according to the situation!
- 在机柜装满电池的场景下，务必留意机柜的重心点，严禁使用吊车仅从机柜顶部吊点起吊，有可能导致机柜损坏！
- In the scenario where the cabinet is filled with batteries, be sure to pay attention to the center of gravity of the cabinet. It is strictly prohibited to use a crane to lift only from the top of the cabinet, as it may cause damage to the cabinet!

<p>OLP 50kW/111kWh 风冷光储一体柜用户手册 OLP 50kW/111kWh Air Cooling Energy Storage Cabinet All-In-One Product User Manual</p>	<p>文件编号： OLP-EIB-V541_E111_P50-AO01-1001 Document number: OLP-EIB-V541_E111_P50-AO01-1001</p>	<p>版本：V0.1 Version:V0.1</p>	<p>Page 42 of 97</p>
<p>© 欧力普能源与自动化技术有限公司 2024 保留所有权利 © Olipower Energy & Automation Technologies 2024 All rights reserved.</p>	<p>地址：深圳市光明区凤凰街道塘尾社区光明大道 380 号尚智科技园 2 栋 A 座 10 楼 Address: 10th Floor, Block A, Building 2, Shangzhi Science and Technology Park, No. 380 Guangming Avenue, Tangwei Community, Fenghuang Street, Guangming District, Shenzhen, China.</p>		<p>Tel: +86 (755) 2650 8686 E-mail: sales@olipower.cn</p>

4.2.1.柜体重心 Center Of Gravity



图 4.2.1 柜体重心示意图

Figure 4.2.1 Schematic diagram of cabinet center of gravity

4.2.2.搬运方式 Handling Method

- 叉车搬运：调整叉车脚宽度尺寸，让重心落在叉车脚中央。
- Forklift handling: Adjust the width and size of the forklift legs to place the center of gravity in the center of the forklift legs.
- 吊车搬运：单根吊装绑带可承受重量不能小于 3000KG，将绑带绑紧箱体。
- Crane handling: A single lifting strap can withstand a weight of no less than 3000KG, and the strap should be tightly tied to the box.

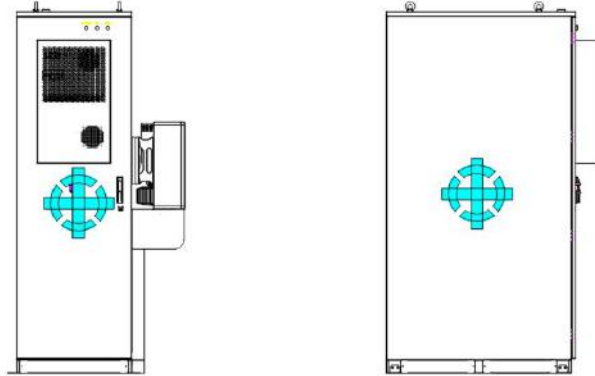

图 4.2.2 叉车以及吊车搬运示意图

Figure 4.2.2 Schematic diagram of forklift and crane handling

<p>OLP 50kW/111kWh 风冷光储一体柜用户手册 OLP 50kW/111kWh Air Cooling Energy Storage Cabinet All-In-One Product User Manual</p>	<p>文件编号： OLP-EIB-V541_E111_P50-AO01-1001 Document number: OLP-EIB-V541_E111_P50-AO01-1001</p>	<p>版本：V0.1 Version:V0.1</p>	<p>Page 43 of 97</p>
<p>© 欧力普能源与自动化技术有限公司 2024 保留所有权利 © Olipower Energy & Automation Technologies 2024 All rights reserved.</p>	<p>地址：深圳市光明区凤凰街道塘尾社区光明大道 380 号尚智科技园 2 栋 A 座 10 楼 Address: 10th Floor, Block A, Building 2, Shangzhi Science and Technology Park, No. 380 Guangming Avenue, Tangwei Community, Fenghuang Street, Guangming District, Shenzhen, China. Tel: +86 (755) 2650 8686 E-mail: sales@olipower.cn</p>		

4.3. 开箱检查 Open Box Inspection

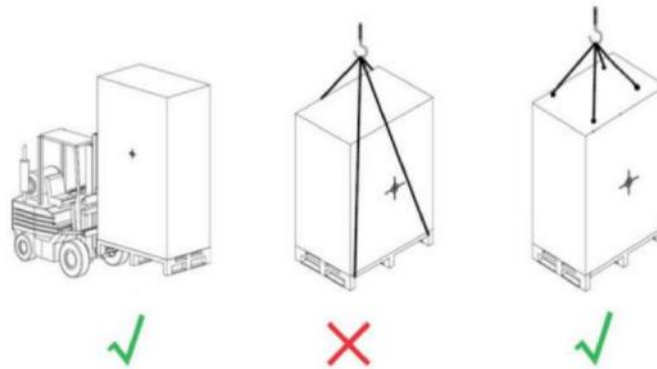
开箱后必须对以下项目进行检查:

After opening the box, the following items must be inspected:

序号 NO.	检查项 Inspection items	确认 Confirm
1	外观无损坏、刮痕、油漆正常 The appearance is undamaged, scratch free, and the paint is normal	
2	产品外包装完好, 无破损、受潮、变形 The outer packaging of the product is intact, without damage, moisture, or deformation	
3	设备内部的连接螺栓无松动, 部件是否有位移、倾斜 The connecting bolts inside the equipment are not loose, and there is no displacement or tilt of the components	

表 4.3 开箱后检查表

Table 4.3 Inspection Checklist after Unboxing

检查清单

序号 No.	名称 Name	描述 Description	数量 QTY	单位 Unit	备注 Note
1	柜体 Cabinet	Dimension 尺寸: 700*1300*2200mm (W*D*H)	1	套 PCS	
1.1	高压箱 High Voltage Control Box	BMU + 高压箱 BMU + High voltage protection	1	套 PCS	
1.2	风冷电池箱 Air-Cooled Battery Packs	77.28V/15.9kWh	7	套 PCS	
1.3	热管理系统 Thermal Management System	空调 Industrial air conditioners	1	套 PCS	
1.4	消防系统 Fire Suppression System	温度探测器 + 感烟探测器 + 气溶胶 Heat Detector + Smoke Detector + Aerosol	1	套 PCS	
1.5	水浸系统 Waterlogging	水浸系统 + 控制器 Waterlogging Sensor +	1	套 PCS	

OLP 50kW/111kWh 风冷光储一体柜用户手册 OLP 50kW/111kWh Air Cooling Energy Storage Cabinet All-In-One Product User Manual	文件编号: OLP-EIB-V541_E111_P50-AO01-1001 Document number: OLP-EIB-V541_E111_P50-AO01-1001	版本: V0.1 Version: V0.1	Page 44 of 97
--	---	---------------------------	---------------

	Alarm System	Controller			
2	混合逆变器 Hybrid Battery Inverter	50kW, 50/60Hz, 3L/N/PE, 220/380V, 230/400V	1	套 PCS	
3	设备配件 Equipment Accessories	电缆槽 Cable trough	1		
		反向电能表 + CT Anti-reverse flow electricity meter + CT	1	件 Set	
		电池电缆 Battery cable	1	件 Set	
		通信线 Communication line	1	件 Set	

表 4.3-2 设备清单

Table 4.3-2 Equipment list

4.4. 柜体安装 Cabinet Installation



注意安全 Caution!

柜体安装注意事项:

Precautions for cabinet installation:

- 安装作业时，必须严格遵循安全提示，否则可能导致设备损坏、人身伤害或严重的伤亡事故，请严格遵守安全提示！
- When installing, it is necessary to strictly follow the safety instructions, otherwise it may cause equipment damage, personal injury or serious injury accidents. Please strictly follow the safety instructions!
- 安装必须由专业人员在遵循所有警告提示的条件下，正确进行设备安装！
- The installation must be carried out correctly by professionals while following all warning prompts!
- 请确保安装位置的机械强度足以支撑设备重量，否则会导致机械危险！
- Please ensure that the mechanical strength of the installation location is sufficient to support the weight of the equipment, otherwise it may cause mechanical danger!
- 请勿穿着宽松的衣服或佩戴饰品，否则可能会有触电的危险！
- Do not wear loose clothing or accessories, as there may be a risk of electric shock!

OLP 50kW/111kWh 风冷光储一体柜用户手册 OLP 50kW/111kWh Air Cooling Energy Storage Cabinet All-In-One Product User Manual	文件编号: OLP-EIB-V541_E111_P50-AO01-1001 Document number: OLP-EIB-V541_E111_P50-AO01-1001	版本: V0.1 Version: V0.1	Page 45 of 97
© 欧力普能源与自动化技术有限公司 2024 保留所有权利 © Olipower Energy & Automation Technologies 2024 All rights reserved.	地址: 深圳市光明区凤凰街道塘尾社区光明大道 380 号尚智科技园 2 栋 A 座 10 楼 Address: 10th Floor, Block A, Building 2, Shangzhi Science and Technology Park, No. 380 Guangming Avenue, Tangwei Community, Fenghuang Street, Guangming District, Shenzhen, China.		Tel: +86 (755) 2650 8686 E-mail: sales@olipower.cn

4.4.1. 逆变器安装 Inverter Installation

1. 背挂安装 Back-mounted installation

背挂安装尺寸 (mm) Back-mounted installation dimensions (mm)



图 4.4.1-1 背挂尺寸

Figure 4.4.1-1 Back-mounted installation dimensions (mm)

2. 使用 4 个螺栓 (在柜子侧面提供) 将逆变器支架固定到柜子的一侧。

Fix the inverter bracket to the side of the cabinet with 4 bolts (provided on the side of the cabinet).

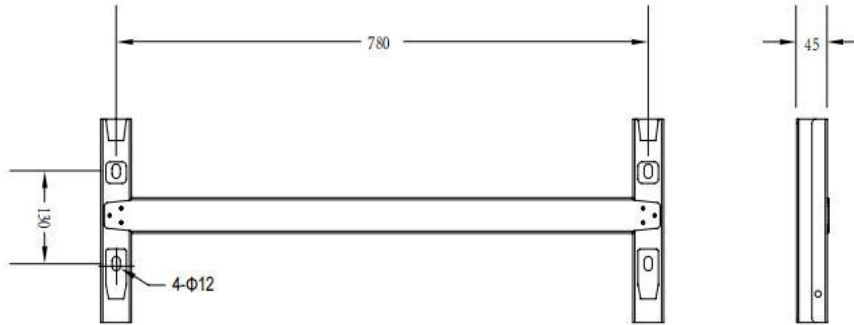

图 4.4.1-2 固定支架

Figure 4.4.1-2 Fixed Bracket

3. 逆变器安装，抬起逆变器，将逆变器背面轨道槽小心地挂在背挂支架上。用 M6 螺栓固定（两边）。

Inverter installation: Lift the inverter and carefully hang the track slot on the back-mounted bracket. Fix (both sides) with M6 bolts.

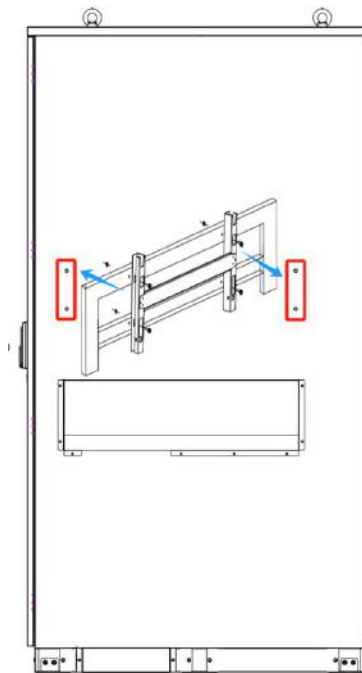

图 4.4.1-3 安装逆变器

Figure 4.4.1-3 Inverter

4. 逆变器外壳接地连接，逆变器外壳与接地排通过 PE 线连接，达到接地保护的目的。请务必牢记先接线 PE 线，再接线其他线。

The inverter housing is grounded. The inverter housing is connected to the grounding bar through a PE line to achieve the purpose of grounding protection. Please remember to connect the PE line first and then the other lines.

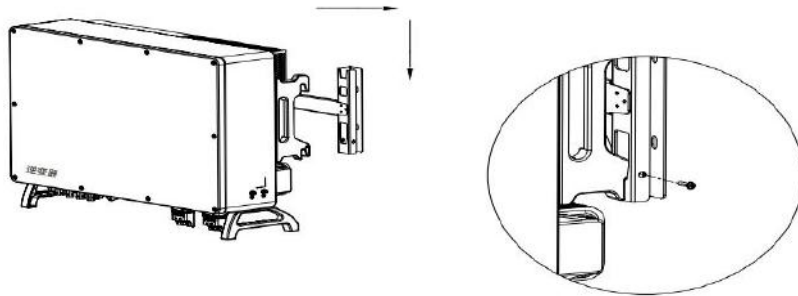
！危险：不得将 N 线作为保护地线连接到逆变器上套管，否则可能引起电击。

！Danger: Do not connect the N wire as a protective ground wire to the bushing on the inverter, otherwise it may cause electric shock.

！提醒：可靠的接地有利于抵抗浪涌电压冲击，提高电磁干扰性能。逆变器必须良好接地。对于只有一个逆变器的系统，只需接地 PE 线即可。对于多逆变器系统，所有逆变器 PE 线应接在同一接地铜排上，以保证等电位连接。

！Reliable grounding is beneficial for resisting surge voltage impacts and enhancing electromagnetic interference performance. The inverter must be well grounded. For a system with only one inverter, it is only necessary to ground the PE wire. For multi-inverter systems, all PE lines of the inverters should be connected to the same grounding copper bar to ensure equipotential bonding.

5. 地端子连接步骤：

Grounding terminal connection steps:

5.1. 外壳接地端子位于逆变器右下方。

The grounding terminal of the casing is located at the lower right corner of the inverter.

5.2. 用合适的工具将接地端固定在 PE 线上，并将接地端锁在逆变器右下方的接地孔上。

<p>OLP 50kW/111kWh 风冷光储一体柜用户手册 OLP 50kW/111kWh Air Cooling Energy Storage Cabinet All-In-One Product User Manual</p>	<p>文件编号： OLP-EIB-V541_E111_P50-AO01-1001 Document number: OLP-EIB-V541_E111_P50-AO01-1001</p>	<p>版本：V0.1 Version:V0.1</p>	<p>Page 47 of 97</p>
<p>© 欧力普能源与自动化技术有限公司 2024 保留所有权利 © Olipower Energy & Automation Technologies 2024 All rights reserved.</p>	<p>地址：深圳市光明区凤凰街道塘尾社区光明大道 380 号尚智科技园 2 栋 A 座 10 楼 Address: 10th Floor, Block A, Building 2, Shangzhi Science and Technology Park, No. 380 Guangming Avenue, Tangwei Community, Fenghuang Street, Guangming District, Shenzhen, China.</p>		<p>Tel: +86 (755) 2650 8686 E-mail: sales@olipower.cn</p>

Use appropriate tools to fix the grounding terminal on the PE line and lock the grounding terminal on the grounding hole at the lower right corner of the inverter.



图 4.4.1-4 接地端子连接

Figure 4.4.1-4 Grounding terminal connection

4.4.2. 机柜安装 Cabinet Installation

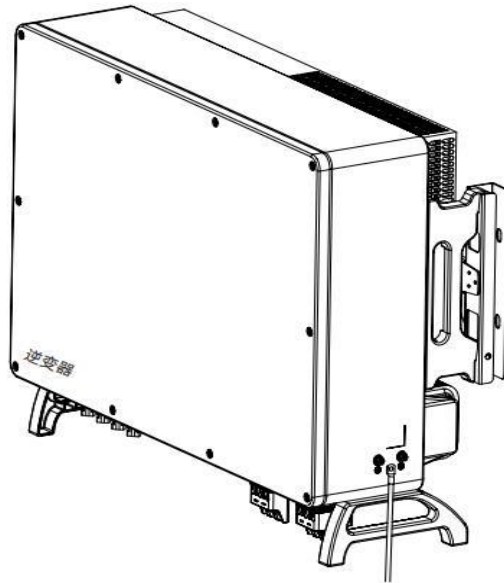

图 4.4.2-1 机柜安装固定孔位尺寸示意图

Figure 4.4.2-1 Schematic diagram of fixed hole size for cabinet installation

<p>OLP 50kW/111kWh 风冷光储一体柜用户手册 OLP 50kW/111kWh Air Cooling Energy Storage Cabinet All-In-One Product User Manual</p> <p>© 欧力普能源与自动化技术有限公司 2024 保留所有权利 © Olipower Energy & Automation Technologies 2024 All rights reserved.</p>	<p>文件编号: OLP-EIB-V541_E111_P50-AO01-1001 Document number: OLP-EIB-V541_E111_P50-AO01-1001</p> <p>地址: 深圳市光明区凤凰街道塘尾社区光明大道 380 号尚智科技园 2 栋 A 座 10 楼 Address: 10th Floor, Block A, Building 2, Shangzhi Science and Technology Park, No. 380 Guangming Avenue, Tangwei Community, Fenghuang Street, Guangming District, Shenzhen, China.</p>	<p>版本: V0.1 Version: V0.1</p>	<p>Page 48 of 97</p> <p>Tel: +86 (755) 2650 8686 E-mail: sales@olipower.cn</p>
---	---	-----------------------------------	--

安装间隙 Installation Gap

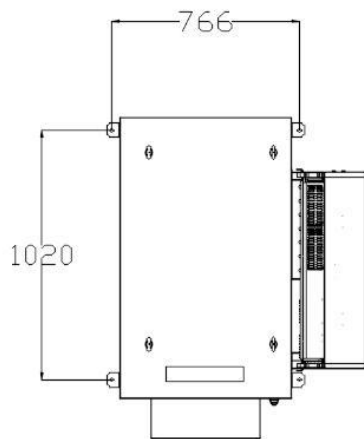
- 机柜前面靠墙以与及其他建筑物的距离大于或者等于 1300mm（便于开门及检修）。
- The distance between the cabinet and other buildings in front of the wall should be greater than or equal to 1300mm (for easy opening and maintenance).
- 机柜后面靠墙以与及其他建筑物的距离大于或者等于 500mm（便于开门及检修）。
- The distance between the cabinet and other buildings behind the wall should be greater than or equal to 500mm (for easy opening and maintenance).
- 机柜侧面靠墙以及与其他建筑物的距离大于或者等于 500mm（便于安装）。
- The distance between the side of the cabinet against the wall and other buildings is greater than or equal to 500mm (for easy installation).
- 多个机柜之间排布，机柜之间的距离大于或者等于 50mm（便于安装）。
- Arrange multiple cabinets with a distance of 50mm or more between them (for easy installation).



图 4.4.2-2 柜体安装间隙示意图（单位 mm）

Figure 4.4.2-2 Schematic diagram of cabinet installation gap (unit: mm)

4.4.3. 安装孔位 Installation Hole Position

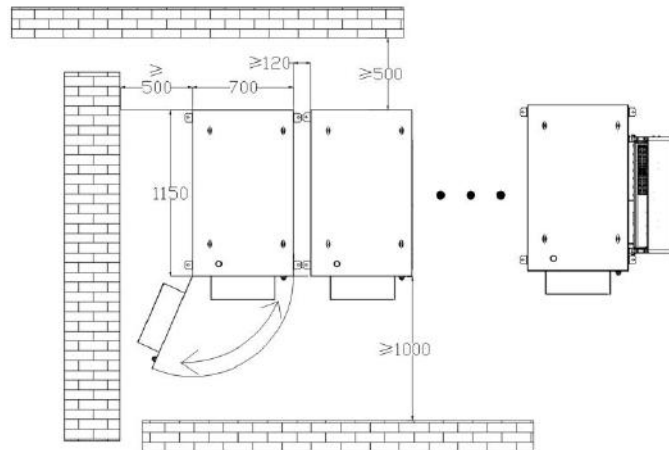

图 4.4.3 机柜安装固定孔位尺寸示意图

Figure 4.4.3 Schematic diagram of fixed hole size for cabinet installation

4.4.4. 地基 Foundation

- 预埋件下部固定在硬化地面上，上部使用螺栓连接固定设备。
- The lower part of the embedded parts is fixed on the hardened ground, and the upper part is connected to the fixed equipment with bolts.
- 穿线钢管分为功率进线管和信号线进线管（预留）。
- The threading steel pipe is divided into power inlet pipe and signal inlet pipe (reserved).
- 施工时，应保证设备底部高于当地历史最高水位。
- During construction, it should be ensured that the bottom of the equipment (is above the local historical highest water level.
- 设备（包含高度、预埋部分、穿线管等）结合工艺和现场调整。
- Equipment (including height, pre embedded parts, conduit, etc.) should be adjusted according to the process and on-site conditions.

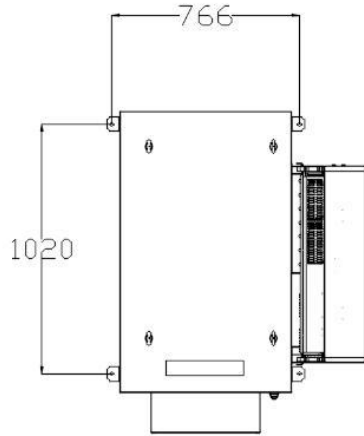
如采用地沟的走线方式，则地沟要求：

If the wiring method of the trench is adopted, the trench requirements are:

- 设备机柜采用下进线的方式，为防止异物进入，机柜侧面未留进线孔。
- The equipment cabinet adopts a bottom entry method, and to prevent foreign objects from entering, there is no wire hole left on the side of the cabinet.

OLP 50kW/111kWh 风冷光储一体柜用户手册 OLP 50kW/111kWh Air Cooling Energy Storage Cabinet All-In-One Product User Manual	文件编号： OLP-EIB-V541_E111_P50-AO01-1001 Document number: OLP-EIB-V541_E111_P50-AO01-1001	版本：V0.1 Version:V0.1	Page 50 of 97
© 欧力普能源与自动化技术有限公司 2024 保留所有权利 © Olipower Energy & Automation Technologies 2024 All rights reserved.	地址：深圳市光明区凤凰街道塘尾社区光明大道 380 号尚智科技园 2 栋 A 座 10 楼 Address: 10th Floor, Block A, Building 2, Shangzhi Science and Technology Park, No. 380 Guangming Avenue, Tangwei Community, Fenghuang Street, Guangming District, Shenzhen, China.		Tel: +86 (755) 2650 8686 E-mail: sales@olipower.cn

- 地沟必须有必要的防尘防鼠设计，防止异物进入。
- The trench must have necessary dust-proof and rodent proof design to prevent foreign objects from entering.
- 地沟中需要有必要的防水防潮设计，防止线缆老化短路。
- Necessary waterproof and moisture-proof design is required in the trench to prevent cable aging and short circuit.
- 地沟设计时需要充分考虑到线缆的截面积与弯曲半径。
- When designing trenches, it is necessary to fully consider the cross-sectional area and bending radius of cables.



图 4.4.4 地面地基尺寸与要求示意图

Figure 4.4.4 Schematic diagram of ground foundation dimensions and requirements

4.4.5. 固定 Fixing

固定步骤: Fixed steps:

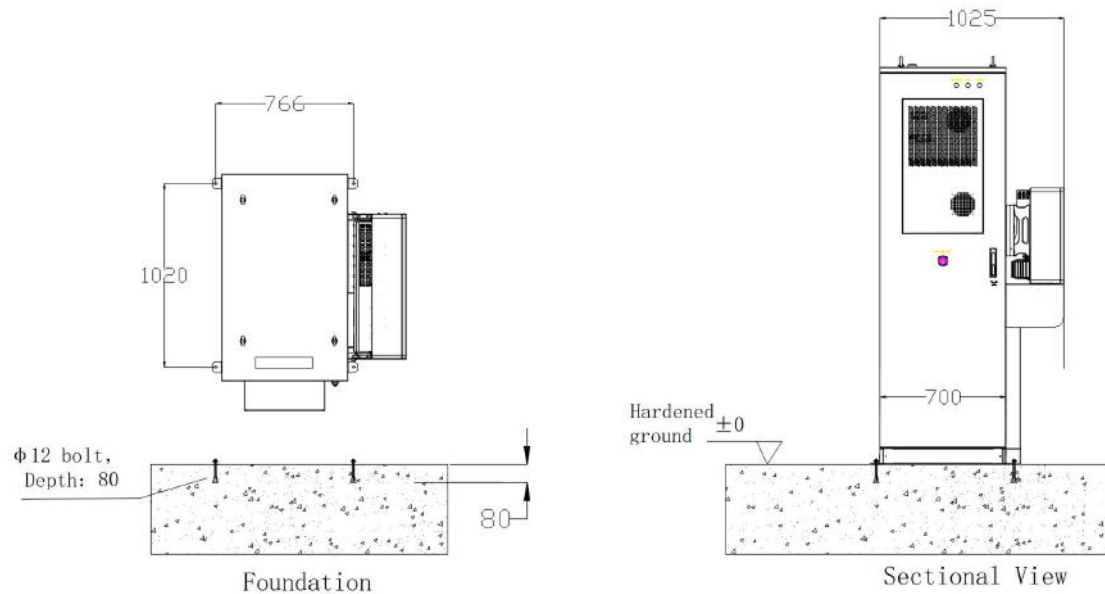
- 确认安装平面上的固定孔位和机柜的底部安装孔位一致。
- Confirm that the fixed holes on the installation plane are consistent with the bottom installation holes of the cabinet.
- Move the cabinet to the installation location.
- 将机柜搬运到安装位置。
- Move the cabinet to the installation location.
- 对准螺孔，并用 4 颗 M12 螺钉将设备固定在槽钢或地基上，安装扭矩为 300N.m。
- Align the screw holes and fix the equipment on the channel steel or foundation

<p>OLP 50kW/111kWh 风冷光储一体柜用户手册 OLP 50kW/111kWh Air Cooling Energy Storage Cabinet All-In-One Product User Manual</p>	<p>文件编号: OLP-EIB-V541_E111_P50-AO01-1001 Document number: OLP-EIB-V541_E111_P50-AO01-1001</p>	<p>版本: V0.1 Version:V0.1</p>	<p>Page 51 of 97</p>
<p>© 欧力普能源与自动化技术有限公司 2024 保留所有权利 © Olipower Energy & Automation Technologies 2024 All rights reserved.</p>	<p>地址: 深圳市光明区凤凰街道塘尾社区光明大道 380 号尚智科技园 2 栋 A 座 10 楼 Address: 10th Floor, Block A, Building 2, Shangzhi Science and Technology Park, No. 380 Guangming Avenue, Tangwei Community, Fenghuang Street, Guangming District, Shenzhen, China.</p>		<p>Tel: +86 (755) 2650 8686 E-mail: sales@olipower.cn</p>

with 4 M12 screws, with an installation torque of 300N. m.

4.5. 电气安装 Electrical Installation

注意安全 Caution!

电气安装注意事项:

Precautions for Electrical Installation:

为保证安装人员的生命安全，在对本产品进行电气安装时必须有必要的安全防护措施，进行电气安装时，必须遵循以下规程：

To ensure the safety of installation personnel, necessary safety protection measures must be taken during electrical installation of this product. The following regulations must be followed during electrical installation:

- 必须是专业人员才能对机柜进行安装，安装过程中严格按照用户手册指导进行！
- Professional personnel are required to install the cabinet, strictly following the instructions in the user manual during the installation process!
- 安装人员必须遵守所在国家或地区的相关电气操作规范！
- Installation personnel must comply with the relevant electrical operation regulations of the country or region where they are located!
- 不允许在带电状态下安装！
- Installation while live is not allowed!
- 安装前，必须将机柜外部的连线断开，确保机柜内所有元件都处于无电状态！
- Before installation, the external wiring of the cabinet must be disconnected to ensure that all components inside the cabinet are in a dead state!
- 必须在断电位置留警示标志，必要时用锁锁止，以防止在安装过程中被重新上电！
- Warning signs must be left at the power-off location, and if necessary, locked with a lock to prevent being re powered on during installation!
- 逆变器导电部分电压过高，可能会对人造成电击。安装逆变器时，请确保交流电源和电源的开关正常逆变器的直流侧完全断电。
- 不要将 N 线作为保护地线连接到逆变器上套管。否则可能引起电击。
- PV 串的正负极不接地，否则会对逆变器造成严重损坏。
- 静电可能会损坏逆变器的电子元件。在安装和安装过程中应采取防静电措施维护。
- 请勿使用附件包装外的其他品牌或其他型号的端子。我们有权拒绝所有申请端子混用造成的损坏。
- 湿气和灰尘会损坏逆变器，请确保电缆接头的密封性。如果逆变器由于电缆连接器连接不良而损坏，保修索赔将无效。

<p>OLP 50kW/111kWh 风冷光储一体柜用户手册 OLP 50kW/111kWh Air Cooling Energy Storage Cabinet All-In-One Product User Manual</p>	<p>文件编号： OLP-EIB-V541_E111_P50-AO01-1001 Document number: OLP-EIB-V541_E111_P50-AO01-1001</p>	<p>版本：V0.1 Version:V0.1</p>	<p>Page 52 of 97</p>
<p>© 欧力普能源与自动化技术有限公司 2024 保留所有权利 © Olipower Energy & Automation Technologies 2024 All rights reserved.</p>	<p>地址：深圳市光明区凤凰街道塘尾社区光明大道 380 号尚智科技园 2 栋 A 座 10 楼 Address: 10th Floor, Block A, Building 2, Shangzhi Science and Technology Park, No. 380 Guangming Avenue, Tangwei Community, Fenghuang Street, Guangming District, Shenzhen, China.</p>		<p>Tel: +86 (755) 2650 8686 E-mail: sales@olipower.cn</p>

4.5.1.接线检查 Wiring Inspection

接线作业前，确保完成如下检查：

Before wiring operations, ensure that the following checks are completed:

- 接线时使用到的线缆已符合相应的线径和屏蔽等要求。
- The cables used for wiring have met the corresponding requirements for wire diameter and shielding.
- 保证设备和产品良好接地。
- Ensure good grounding of equipment and products.
- 线的相关选配件已准备就绪。
- The relevant accessories for wiring are ready.
- 线缆需要满足电压绝缘等级，有必要的防护，避免线缆绝缘皮有划伤划破的情况。
- The cable needs to meet the voltage insulation level and have necessary protection to avoid scratching the insulation skin of the cable.

接线作业后，确保完成如下检查：

After the wiring operation, ensure that the following checks are completed:

- 测量进线侧电压是否在规定范围内，确认不存在缺相，短路等故障。
- Measure whether the voltage on the incoming side is within the specified range and confirm that there are no faults such as phase loss or short circuit.
- 电源输入端子已经进行正确连接并且牢固可靠。
- The power input terminal has been correctly connected and securely fastened.
- 接地线已经可靠接地。
- The grounding wire has been reliably grounded.

<p>OLP 50kW/111kWh 风冷光储一体柜用户手册 OLP 50kW/111kWh Air Cooling Energy Storage Cabinet All-In-One Product User Manual</p>	<p>文件编号： OLP-EIB-V541_E111_P50-AO01-1001 Document number: OLP-EIB-V541_E111_P50-AO01-1001</p>	<p>版本：V0.1 Version:V0.1</p>	<p>Page 53 of 97</p>
--	---	---------------------------------	----------------------

4.5.2.接线说明 Wiring Instructions



图 4.5.2-1 逆变器接口说明

Figure 4.5.2-1 Inverter Interface Description

接线端子位于逆变器的底部，如下图所示。

Wiring terminals are at the bottom of the inverter, as shown in the table below.

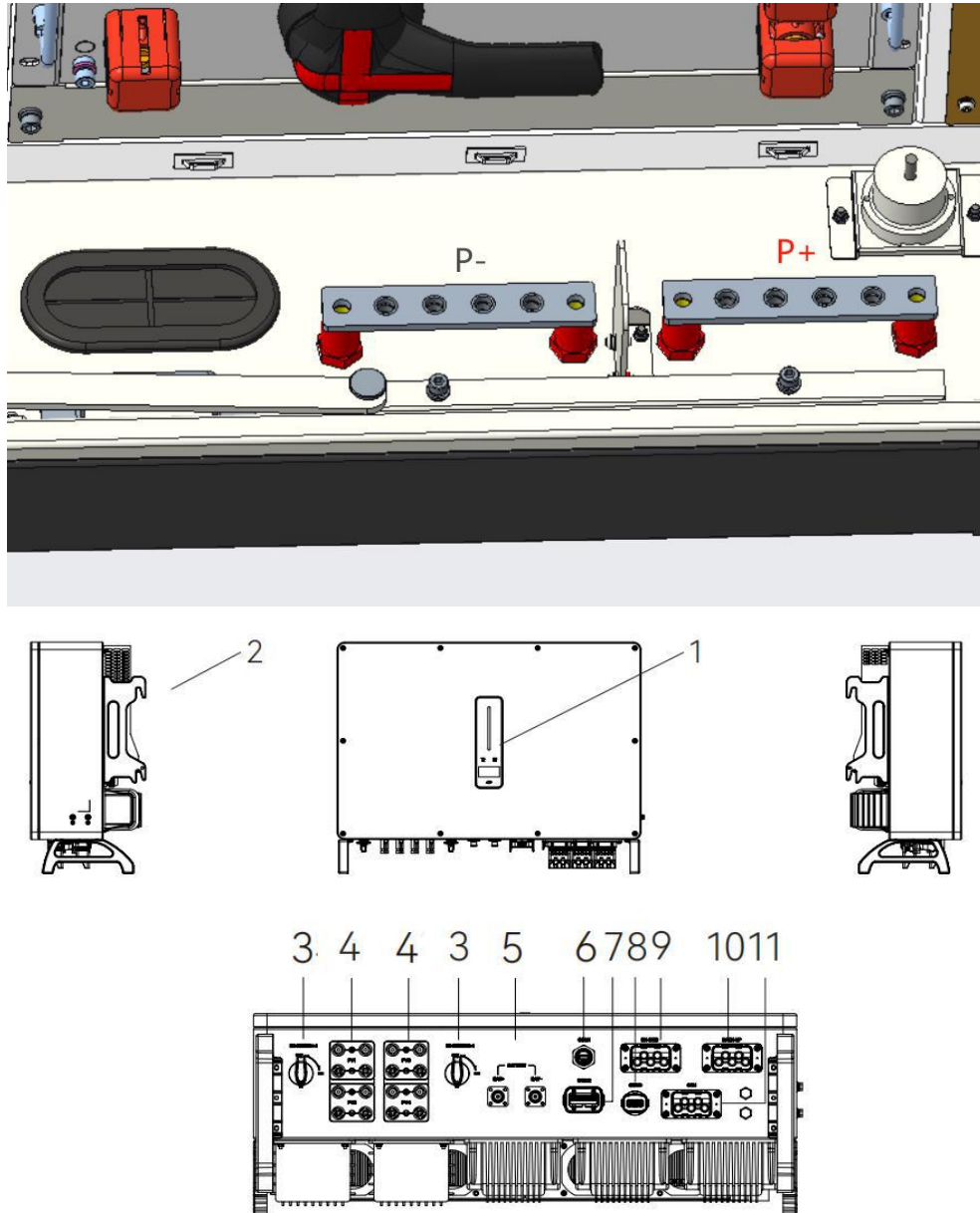
序号	定义	备注
----	----	----

<p>OLP 50kW/111kWh 风冷光储一体柜用户手册 OLP 50kW/111kWh Air Cooling Energy Storage Cabinet All-In-One Product User Manual</p>	<p>文件编号: OLP-EIB-V541_E111_P50-AO01-1001 Document number: OLP-EIB-V541_E111_P50-AO01-1001</p>	<p>版本: V0.1 Version:V0.1</p>	<p>Page 54 of 97</p>
<p>© 欧力普能源与自动化技术有限公司 2024 保留所有权利 © Olipower Energy & Automation Technologies 2024 All rights reserved.</p>	<p>地址: 深圳市光明区凤凰街道塘尾社区光明大道 380 号尚智科技园 2 栋 A 座 10 楼 Address: 10th Floor, Block A, Building 2, Shangzhi Science and Technology Park, No. 380 Guangming Avenue, Tangwei Community, Fenghuang Street, Guangming District, Shenzhen, China.</p>		
			<p>Tel: +86 (755) 2650 8686 E-mail: sales@olipower.cn</p>

No.	Delimiting	Remark
P+	高压控制箱正极 HV Box Positive Pole	用于连接逆变器电池输入端子正极 It is used to connect the positive terminal of the inverter battery input terminal
P-	高压控制箱负极 HV Box Negative Pole	用于连接逆变器电池输入端子负极 It is used to connect the negative terminal of the inverter battery input terminal
1	显示屏和 LED 面板 Display and LED panel	显示逆变器的操作信息和工作状态。 Display the operation information and working states of the inverter.
2	挂钩 Hanger	用于将逆变器挂在壁挂支架上。 Used to hang the inverter on the wall-mounting bracket.
3	直流开关 DC switch	用于安全断开直流电路。 Used to safely disconnect the DC circuit.
4	直流输入端子 DC input terminal	光伏连接器 (MHT-25~50K 8 对/MHT-40~50K-P 6 对) PV connector (MHT-25~50K 8 pairs/ MHT-40~50K-P 6 pairs)
5	电池输入端子 Battery input terminal	电池连接器 Battery connector
6	COM1 端口 COM1 port	WiFi/LAN/4G 模块连接器 WiFi/LAN/4G module connector
7	COM2 端口 COM2 port	仪表/BMS/RS488/DRED/DO 连接器 Meter/BMS/RS485/DRED/DO Connector
8	COM3 端口 COM3 port	DO/0-10V AO/4-20mA AO 连接器 DO/0-10V AO/4-20mA AO Connector
9	并网输出端子 On-grid output terminal	用于并网输出电缆连接 Used for On-grid output cable connection
10	备用输出端子 Back-up output terminal	用于备份输出电缆连接 Used for Back-up output cable connection
11	发电机输入端子 Generator input terminal	发电机连接器 (此功能暂时不可用。 (This function is temporarily unavailable)

表 4.5.2-2 逆变器接口说明

Table 4.5.2-2 Inverter Interface Description

注意 Attention::

通讯线使用屏蔽双绞线。

Use shielded twisted pair cables for comm lines.

OLP 50kW/111kWh 风冷光储一体柜用户手册 OLP 50kW/111kWh Air Cooling Energy Storage Cabinet All-In-One Product User Manual	文件编号: OLP-EIB-V541_E111_P50-AO01-1001 Document number: OLP-EIB-V541_E111_P50-AO01-1001	版本: V0.1 Version: V0.1	Page 55 of 97
© 欧力普能源与自动化技术有限公司 2024 保留所有权利 © Olipower Energy & Automation Technologies 2024 All rights reserved.	地址: 深圳市光明区凤凰街道塘尾社区光明大道 380 号尚智科技园 2 栋 A 座 10 楼 Address: 10th Floor, Block A, Building 2, Shangzhi Science and Technology Park, No. 380 Guangming Avenue, Tangwei Community, Fenghuang Street, Guangming District, Shenzhen, China.		
			Tel: +86 (755) 2650 8686 E-mail: sales@olipower.cn

4.5.3. 电气接线图 Electrical Wiring diagram

此图为 25~50K 系列储能逆变器的接线结构及组成，就实际工程而言，安装及接线均须符合当地标准。

This figure shows the wiring structure and composition of the 25-50K series energy storage inverters. In actual engineering, both installation and wiring must comply with local standards.

智能电表包括 ACR10R 和 SM。具体接线请参考章节 4.5.6。以下电表接线图仅供参考。

Smart electricity meters include ACR10R and SM. For specific wiring, please refer to Section 4.5.6. The following electricity meter wiring diagram is for reference only.



图 4.5.3-1 电路图

Figure 4.5.3-1 Circuit diagram

单台逆变器接线图 Wiring diagram of a single inverter

本图为示例，对电气线路连接无特殊要求。交流电源的 N 线可以隔离或开关处理。

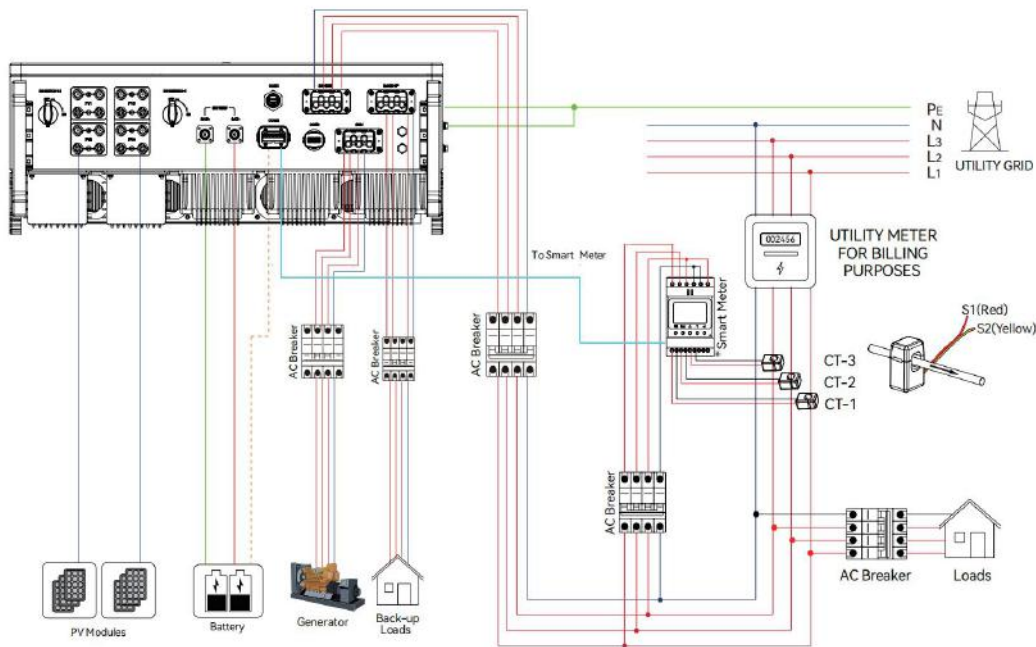
This picture is an example. There are no special requirements for the connection of electrical circuits. The N line of the AC power supply can be isolated or switched on.

智能电表包括 ACR10R 和 SM。具体接线请参考章节 4.5.6。以下电表接线图仅供参考。

12(L)*/13(N)*仅适用于 ACR10R，11(PE)*仅适用于 SM。

Smart electricity meters include ACR10R and SM. For specific wiring, please refer

<p>OLP 50kW/111kWh 风冷光储一体柜用户手册 OLP 50kW/111kWh Air Cooling Energy Storage Cabinet All-In-One Product User Manual</p>	<p>文件编号: OLP-EIB-V541_E111_P50-AO01-1001 Document number: OLP-EIB-V541_E111_P50-AO01-1001</p>	<p>版本: V0.1 Version:V0.1</p>	<p>Page 56 of 97</p>
<p>© 欧力普能源与自动化技术有限公司 2024 保留所有权利 © Olipower Energy & Automation Technologies 2024 All rights reserved.</p>	<p>地址: 深圳市光明区凤凰街道塘尾社区光明大道 380 号尚智科技园 2 栋 A 座 10 楼 Address: 10th Floor, Block A, Building 2, Shangzhi Science and Technology Park, No. 380 Guangming Avenue, Tangwei Community, Fenghuang Street, Guangming District, Shenzhen, China.</p>		<p>Tel: +86 (755) 2650 8686 E-mail: sales@olipower.cn</p>

to Section 4.5.6. The following electricity meter wiring diagram is for reference only. 12(L)*/13(N)* only applicable to ACR10R, 11(PE)* only applicable to SM.

4.5.4.AC 连接 AC Connection

1. AC 端要求 AC terminal requirements

- 并网输出侧和备用输出侧都需要连接一个独立的交流断路器,任何负载都不能直接与逆变器连接。
 - Both the grid-connected output side and the standby output side need to be connected to an independent AC circuit breaker. No load can be directly connected to the inverter.
 - 在连接交流电缆之前,请确认所有直流和交流电源都已从设备上断开。
 - Before connecting the AC cable, please make sure that all DC and AC power sources have been disconnected from the device.
 - 25~50K 系列三相高压储能逆变器适用于电压为的三相电网 230/400V,频率为 50/60Hz 的三相电网。
 - The 25~50K series three-phase high-voltage energy storage inverter is suitable for three-phase power grids with a voltage of 230/400V and a frequency of 50/60Hz.
 - 逆变器必须经当地电力公司批准后才能接入电网。
 - Inverters must be approved by the local power company before being connected to the power grid.
 - 25~50K 交流侧需安装三相交流断路器。为确保 25~50K 在异常情况下能够安全断开与电网的连接,选择过流保护装置时应参照当地配电规定和最大交流侧输入(输出)电流。
 - Three-phase AC circuit breakers need to be installed on the 25-50K AC side. To ensure that 25 to 50K can safely disconnect from the power grid in abnormal conditions, when choosing an overcurrent protection device, local distribution regulations and the maximum AC side input (output) current should be referred to.
 - 25~50K 的交流电缆允许的线径和截面积如下图所示:
 - The allowable wire diameter and cross-sectional area of 25-50K AC cables are shown in the following figure:
- ! 提醒: 请检查交流断路器的过流能力,以实际情况为准。**
- ! Reminder: Please check the overcurrent capacity of the AC circuit breaker. The actual situation shall prevail.

<p>OLP 50kW/111kWh 风冷光储一体柜用户手册 OLP 50kW/111kWh Air Cooling Energy Storage Cabinet All-In-One Product User Manual</p>	<p>文件编号: OLP-EIB-V541_E111_P50-AO01-1001 Document number: OLP-EIB-V541_E111_P50-AO01-1001</p>	<p>版本: V0.1 Version:V0.1</p>	<p>Page 57 of 97</p>
<p>© 欧力普能源与自动化技术有限公司 2024 保留所有权利 © Olipower Energy & Automation Technologies 2024 All rights reserved.</p>	<p>地址: 深圳市光明区凤凰街道塘尾社区光明大道 380 号尚智科技园 2 栋 A 座 10 楼 Address: 10th Floor, Block A, Building 2, Shangzhi Science and Technology Park, No. 380 Guangming Avenue, Tangwei Community, Fenghuang Street, Guangming District, Shenzhen, China.</p>		<p>Tel: +86 (755) 2650 8686 E-mail: sales@olipower.cn</p>



图 4.5.4-1
Figure 4.5.4-1

2. 漏电流保护装置 (RCD)

漏余电流保护装置，一旦检测到故障电流值超过限制，逆变器将立即与市电断开。

The residual current leakage protection device will immediately disconnect the inverter from the mains power supply once it detects that the fault current value exceeds the limit.

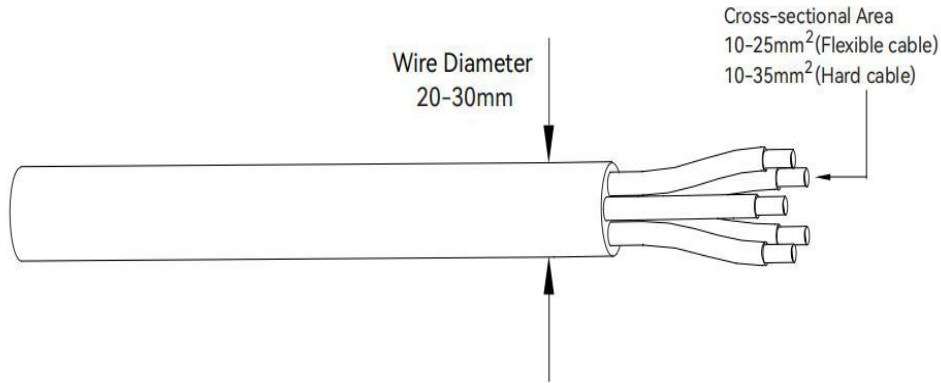
但如果必须配置外部漏电流保护装置 (RCD) (建议为 A 型)，则必须在剩余电流超过限制时触发开关。其他规格的漏电流保护装置也可按当地标准使用。例如，在澳大利亚，安装人员可以使用 30 毫安 (A 型) 漏电流保护装置。

However, if an external leakage current protection device (RCD) (recommended type A) must be configured, the switch must be triggered when the residual current exceeds the limit. Leakage current protection devices of other specifications can also be used in accordance with local standards. For example, in Australia, installers can use A 30 milliamper (Type A) leakage current protection device.

建议的漏电流值极限如下：

The suggested limits of leakage current values are as follows:

机型 Model	漏电流极限值 Leakage current limit value
25kW-100A	300mA
30kW-100A	
36kW-100A	360mA
40kW-100A	400mA
40kW-100A-P	
50kW-100A	500mA

50kW-100A-P	
-------------	--

3. 安装 AC 端子 Install AC Terminal

- 逆变器存在高压危险!
- There is a high voltage risk in the inverter!
- 进行电气连接前, 请确保所有电缆不带电。
- Before making electrical connections, please ensure that all cables are not live.
- 请在逆变器电气连接全部完成后再连接 AC 断路器。
- Please connect the AC circuit breaker only after all the electrical connections of the inverter are completed.
- 交流端子排位于逆变器的底部。
- The AC terminal block is located at the bottom of the inverter.

①密封配件 Sealing accessories

建议的电缆外直径为 20~24mm 和 24.5~30mm。

The recommended outer diameters of the cables are 20 to 24mm and 24.5 to 30mm.

如果电缆外直径超过 24mm, 请拆卸图 4.5.4-2 中 Part 1。

If the outer diameter of the cable exceeds 24mm, please disassemble Part 1 in Figure 4.5.4-2.



图 4.5.4-2

Figure 4.5.4-2

②据图 4.5.4-1 选择合适的线缆, 将线缆的绝缘套筒交流电缆剥去 95-100mm, 将 3L /PE / N 线末端剥去 15mm。

②According to Figure 4.5.4-1, select the appropriate cables. Strip 95-100mm of the insulating sleeve of the AC cable and 15mm of the end of the 3L /PE/N cable.

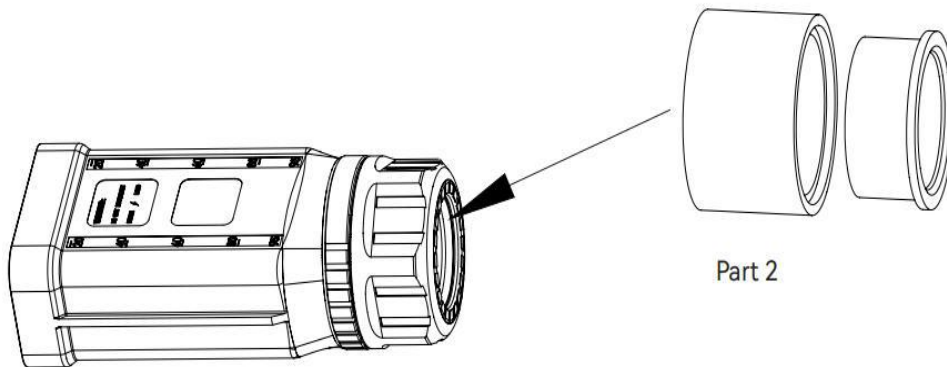

图 4.5.4-3

Figure 4.5.4-3

- ③将剥下来的铜线依次穿入锁紧螺母和主体（多芯多股铜线电缆需要铆接在冷压端子上）。
- ③Pass the stripped copper wire through the lock nut and the main body in sequence. (For multi-core and multi-strand copper wire cables, they need to be riveted to cold-pressed terminals.)。

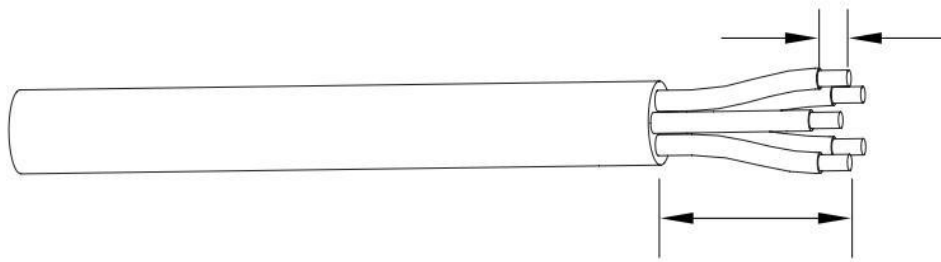

图 4.5.4-4

Figure 4.5.4-4

- ④将电缆按线路顺序插入橡胶芯，通过孔位观察电缆就位，压接螺丝刀力矩为 $5 \pm 0.1 \text{N} \cdot \text{m}$ 。
- ④Insert the cables into the rubber core in the order of the circuit. Observe the cables in place through the holes. The torque of the crimping screwdriver is $5 \pm 0.1 \text{N} \cdot \text{m}$.

！警告：冷压端子必须锁紧，并确保它不会长时间使用后松动。

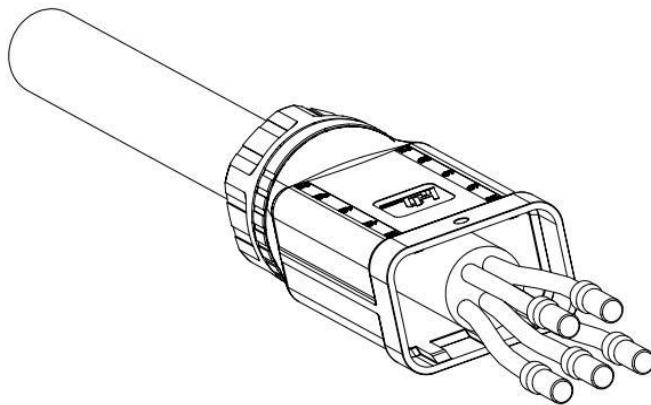
！Warning: Cold-pressed terminals must be locked tightly and ensure that they do not loosen after long-term use.



图 4.5.4-5

Figure 4.5.4-5

⑤将线缆端子前部主体插入橡胶芯内，听到“咔”声，然后使用扳手（扭矩 $10.0 \pm 0.1 \text{N} \cdot \text{m}$ ）拧紧螺母，完成安装。

⑤Insert the main body at the front of the cable terminal into the rubber core. When you hear a "click", then use a wrench (torque $10.0 \pm 0.1 \text{N} \cdot \text{m}$) to tighten the nut to complete the installation.

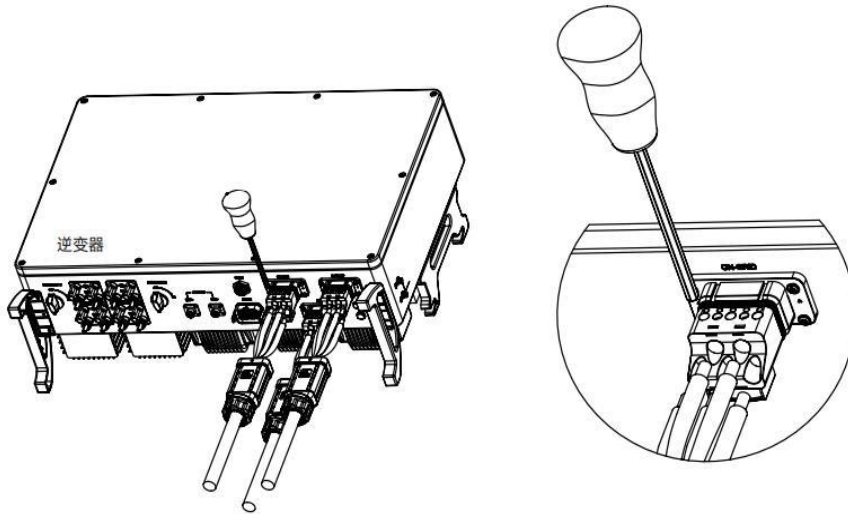

图 4.5.4-5

Figure 4.5.4-5

4. 拆卸 AC 端子 Remove the AC terminal

① 一手握住解锁卡扣，沿标记方向旋转，另一手沿相反方向旋转螺母。

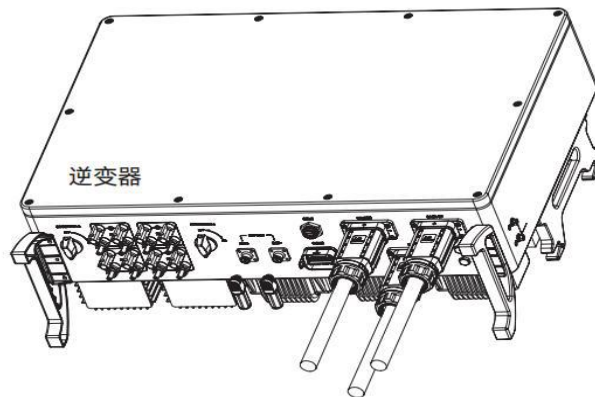
① Hold the unlock latch with one hand and rotate it along the marked direction, while rotate the nut in the opposite direction with the other hand.

② 用螺丝刀对准开锁位置，按住主体并向后拉，即可完成拆卸

OLP 50kW/111kWh 风冷光储一体柜用户手册 OLP 50kW/111kWh Air Cooling Energy Storage Cabinet All-In-One Product User Manual	文件编号： OLP-EIB-V541_E111_P50-AO01-1001 Document number: OLP-EIB-V541_E111_P50-AO01-1001	版本: V0.1 Version:V0.1	Page 61 of 97
© 欧力普能源与自动化技术有限公司 2024 保留所有权利 © Olipower Energy & Automation Technologies 2024 All rights reserved.	地址: 深圳市光明区凤凰街道塘尾社区光明大道 380 号尚智科技园 2 栋 A 座 10 楼 Address: 10th Floor, Block A, Building 2, Shangzhi Science and Technology Park, No. 380 Guangming Avenue, Tangwei Community, Fenghuang Street, Guangming District, Shenzhen, China.		

② Align the screwdriver with the unlocking position, hold down the main body and pull it backward to complete the disassembly.

！注意：请区分 On-grid 侧端子和 Back-up 侧端子，请勿混淆。

！ Note: Please distinguish between the On-grid side terminal and the Back-up side terminal. Do not confuse them.



图 4.5.4-6

Figure 4.5.4-6

4.5.5. 安装监控设备 Install monitoring equipment

25~50K 系列混合逆变器支持 WIFI, LAN 和 4G 通信。将 WIFI / LAN / 4G 模块插入逆变器底部的 COM1 口。一个轻微的安装过程中的“咔哒”声表示安装到位。

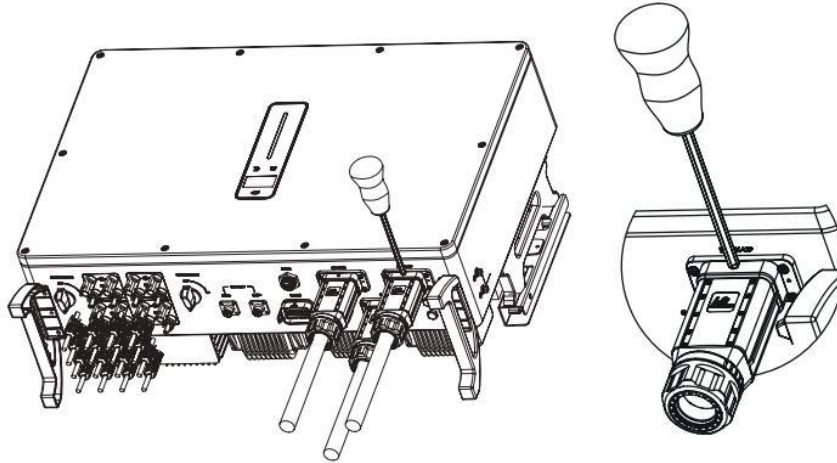
The 25~50K series hybrid inverters support WIFI, LAN and 4G communication. Insert the WIFI/LAN / 4G module into the COM1 port at the bottom of the inverter. A slight "click" sound during the installation process indicates that the installation is in place.



图 4.5.5-1 安装监控设备
Figure 4.5.5-1 Install monitoring equipment

4.5.6.电表和 CT 连接 Connect Meter and CT

电流互感器，也称为 CT，通常安装在房屋负载和电网之间的火线上。

Current transformers, also known as CTS, are usually installed on the live wire between the house load and the power grid.

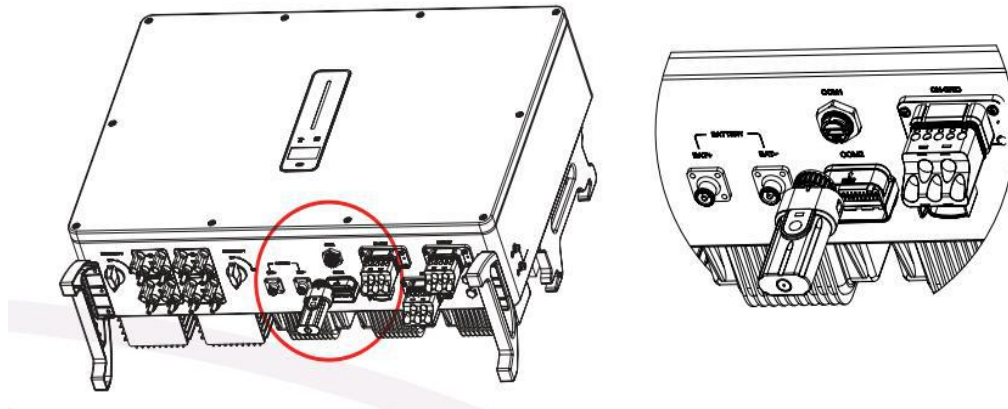
本仪表应安装在交流配电柜或其他儿童不易接触的地方。CT 电缆长度为 2m，是固定的，不能延伸。

This instrument should be installed in an AC distribution cabinet or other places that are not easily accessible to children. The length of the CT cable is 2 meters and it is fixed and cannot be extended.

收到电表时，CT 时已经连接到电表上，按照电表上的接线图连接 CT 即可。

When you receive the electricity meter, the CT has already been connected to it. Just connect the CT according to the wiring diagram on the electricity meter.



图 4.5.6-1

Figure 4.5.6-1

！提醒：

！ Warning:

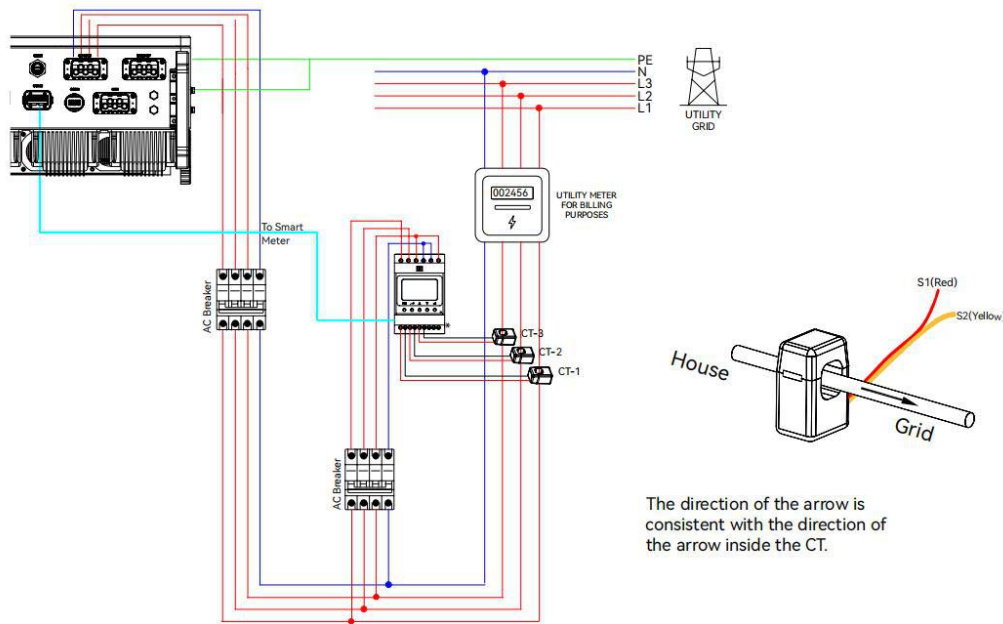
- CT 的安装方向按照箭头方向，由负载指向电网。CT 的安装方向应严格按照用户手册中的说明进行，否则可能导致逆变器无法正常工作。
- The installation direction of the CT should follow the arrow direction, from the load to the power grid. The installation direction of the CT should be strictly carried out in accordance with the instructions in the user manual; otherwise, it may cause the inverter to fail to work properly.
- CT 必须与电表中的端口相对应，并且 CT 与电表之间的连接需要可靠，否则会造成 CT 的损坏可能会影响 CT 测量精度。
- The CT must correspond to the port in the electricity meter, and the connection between the CT and the electricity meter needs to be reliable; otherwise, it may cause damage to the CT and affect the measurement accuracy of the CT.
- 请根据您的需要选择合适的 CT 尺寸。
- Please select the appropriate CT size according to your needs.

电表端子定义如下表所示：

The terminals of the electricity meter are defined as shown in the following table:

<p>OLP 50kW/111kWh 风冷光储一体柜用户手册 OLP 50kW/111kWh Air Cooling Energy Storage Cabinet All-In-One Product User Manual</p>	<p>文件编号： OLP-EIB-V541_E111_P50-AO01-1001 Document number: OLP-EIB-V541_E111_P50-AO01-1001</p>	<p>版本：V0.1 Version:V0.1</p>	<p>Page 64 of 97</p>
<p>© 欧力普能源与自动化技术有限公司 2024 保留所有权利 © Olipower Energy & Automation Technologies 2024 All rights reserved.</p>	<p>地址：深圳市光明区凤凰街道塘尾社区光明大道 380 号尚智科技园 2 栋 A 座 10 楼 Address: 10th Floor, Block A, Building 2, Shangzhi Science and Technology Park, No. 380 Guangming Avenue, Tangwei Community, Fenghuang Street, Guangming District, Shenzhen, China.</p>		<p>Tel: +86 (755) 2650 8686 E-mail: sales@olipower.cn</p>

No.	Definition		Function
	ACR10R	RMM	
1	L1		L1/L2/L3/N connect to grid to detect power grid voltage
2	L2		
3	L3		
4	N		
5	L1-S1		To detect the CT current and direction
6	L1-S2		
7	L2-S1		
8	L2-S2		
9	L3-S1		
10	L3-S2		
11	/	PE	Ground connection
12	L	/	Power supplied from grid
13	N	/	
RS485	/	Reserve	Communicate with hybrid inverter
	RS485	RS485-2	
ANT	/	Reserve	
LAN	/	Reserve	
Type-C	/	Type-C	Specified Debug Interface. Do not use it by non-professionals

4.5.7. 通讯连接 Communication Connection

所有通信端口都在逆变器底部的多功能通信端口中，包括 Meter 端口、CAN 端口、BMS 端口、EMS 端口、DRED 端口、DO 端口、0-10V AO 端口、4-20mA AO 端口。

All communication ports are in the multi-functional communication ports at the bottom of the inverter, including the Meter port, CAN port, BMS port, EMS port, DRED port, DO port, 0-10V AO port, and 4-20mA AO port.



图 4.5.7-1 COM2 端口
Figure 4.5.7-1 COM2 Terminal

Pin	Definition	Function
METER (RJ45-1)	RS 485	Communicate with Meter
BMS (RJ45-1)	CAN	Communicate with BMS
1	COM	DO-1 (Multifunction Relay)
2	NO (Normally Open)	
3	/	Reserved
4	/	Reserved
5	DRM4/8	DRED For Australia and New Zealand
6	DRM3/7	
7	DRM2/6	
8	DRM1/5	
15	COM D/0	Fast stop
16	REF D/0	
11	Fast stop +	EMS
12	Fast stop -	
13	485 B1	CAN for parallel connection of inverters
14	485 A1	
17	CANL_P	Reserved
18	CANH_P	
19	/	Reserved
20	/	Reserved

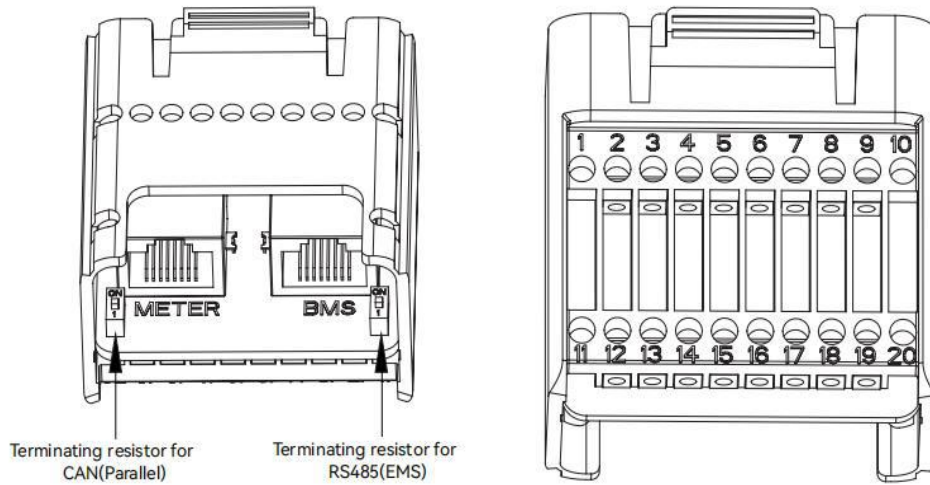

图 4.5.7-2 COM3 端口
Figure 4.5.7-2 COM3 Terminal

Pin	Definition	Function
1-6	/	Reserved
7	COM	DO-2 (Multifunction Relay)
8	NO	
9-10	/	Reserved
11	COM	DO-3 (Multifunction Relay)
12	NC	
13-16	/	Reserved
17	4-20mA_OUT	4-20mA analog output
18	GND	
19	GND	0-10V analog output
20	0-10V_OUT	

➤ 装配多功能端子 Assemble multi-functional terminals

① 从多功能端子上拧下旋转螺母。Unscrew the rotating nut from the multi-functional terminal.

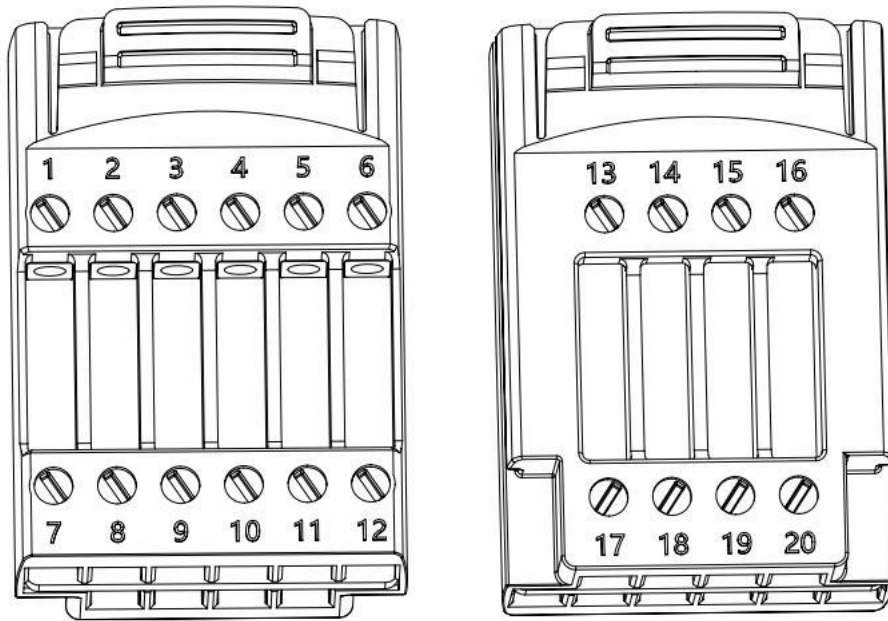

图 4.5.7-3

Figure 4.5.7-3

② 取出端子盒。Take out the terminal box.

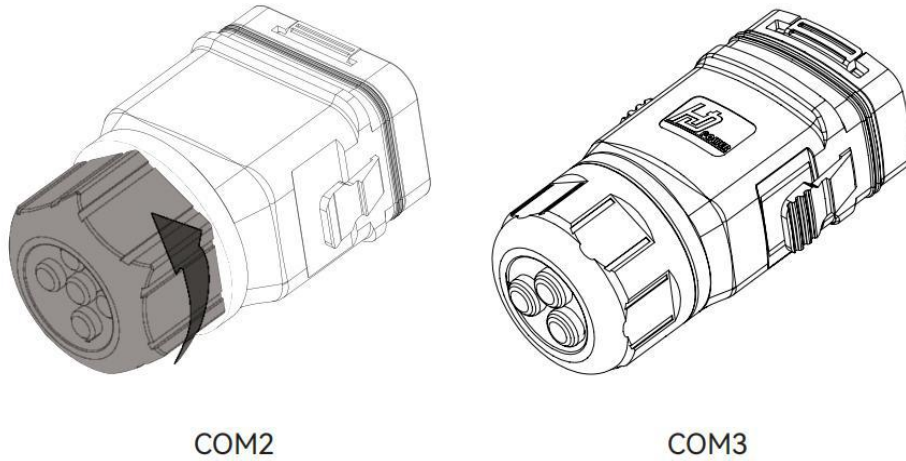

图 4.5.7-4

Figure 4.5.7-4

③ 拆下密封橡胶，将电缆穿过电缆压盖。Remove the sealing rubber and pass the cable through the cable cover.

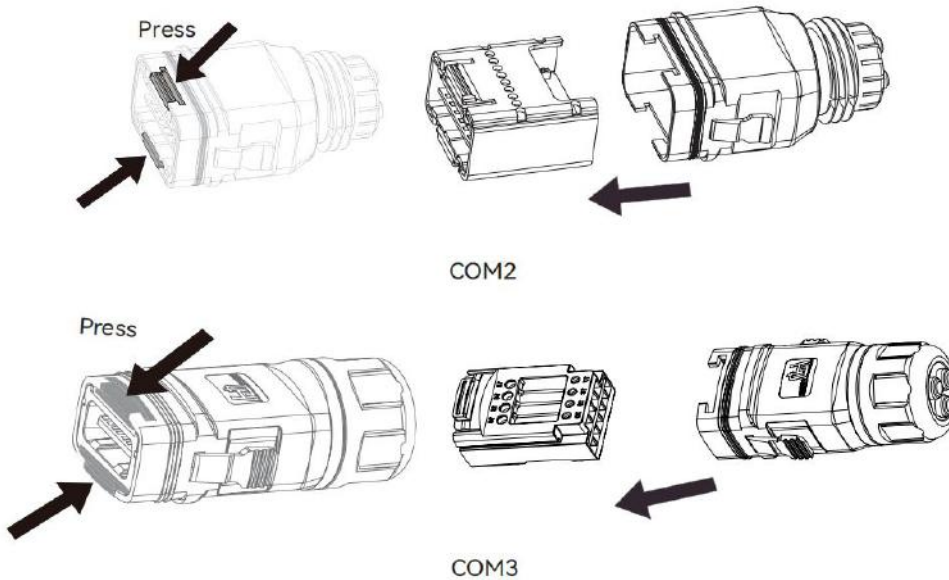

图 4.5.7-5

Figure 4.5.7-5

- 连接电表通讯和 BMS 通信电缆，电表 /BMS 与逆变器之间的通信为 RJ45 接口电缆。
- Connect the communication cables of the electricity meter and BMS. The communication between the electricity meter /BMS and the inverter is an RJ45 interface cable.

① 将合适长度的 RJ45 插头穿过旋转螺母，插入橡胶垫片打开的一侧。Pass an RJ45 plug of the appropriate length through the rotating nut and insert it into the open side of the rubber gasket.

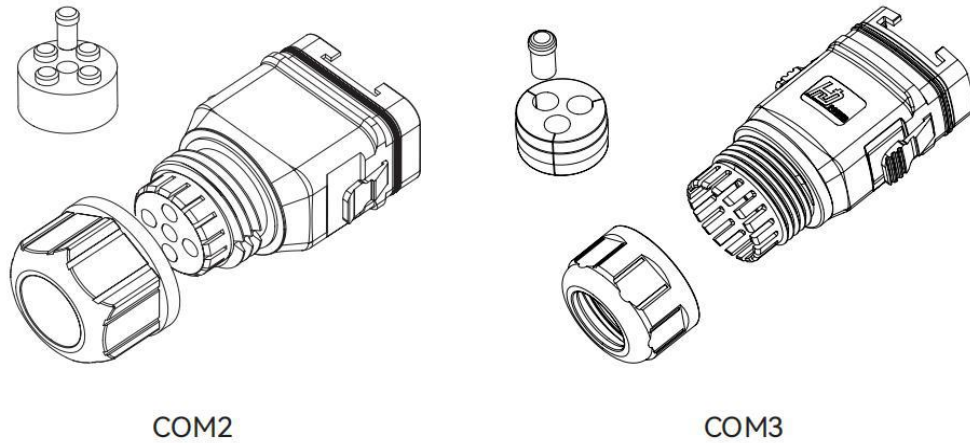

图 4.5.7-6

Figure 4.5.7-6

② 将 RJ45 插头的一端插入端子座的 RJ45 接口。Insert one end of the RJ45 plug into the RJ45 interface of the terminal socket.

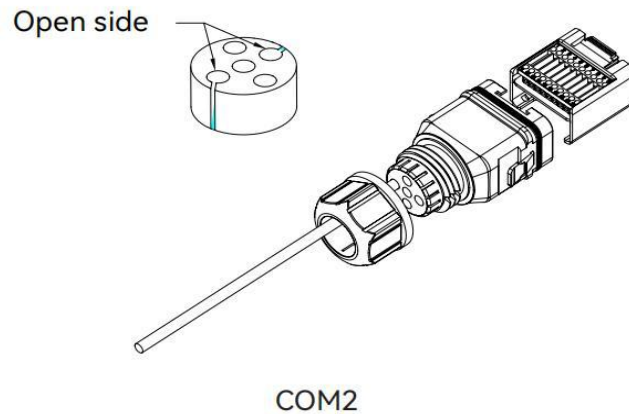
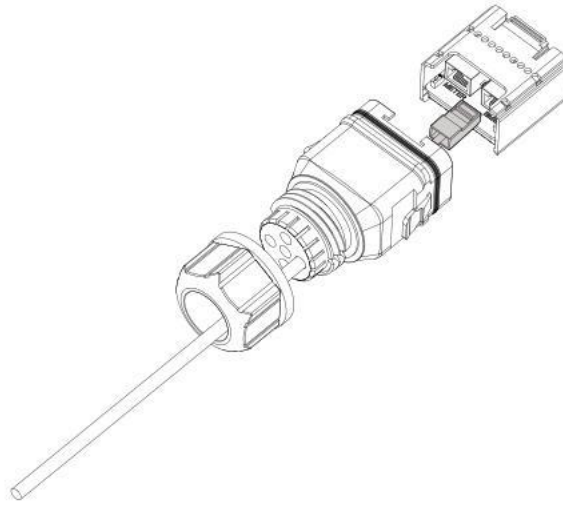

COM2

图 4.5.7-7

Figure 4.5.7-7

③ 将通信线的另一端插入仪表 RS485 接口或 BMS CAN 接口。Insert the other end of the communication line into the RS485 interface or BMS CAN interface of the instrument.

- 连接其他线缆
- Connect other cables

① 将合适长度的电缆穿过旋转螺母和外壳。拆下电缆护套，剥去电线绝缘。Pass a cable of the appropriate length through the rotating nut and the housing. Remove the cable sheath and strip off the insulation of the wire.



图 4.5.7-8

Figure 4.5.7-8

② (可选) 当使用多芯多股铜线电缆时, 线头应连接到冷压端子上 (手动紧固)。如果是单股铜线, 请跳过此步骤。(Optional) When using multi-core and multi-strand copper wire cables, the wire ends should be connected to cold-pressed terminals (manually tightened). If it is a single-strand copper wire, please skip this step.

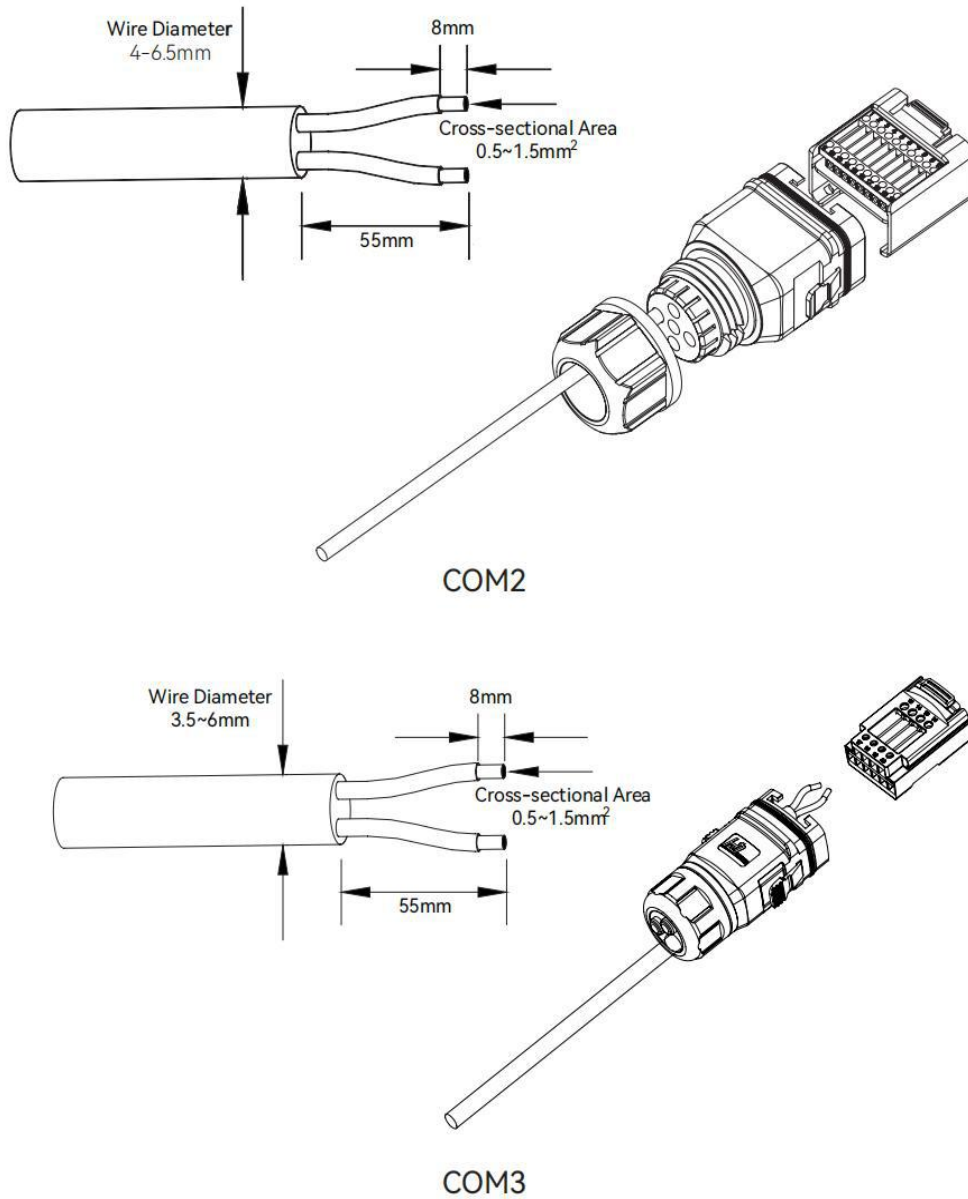

图 4.5.7-9

Figure 4.5.7-9

③ 将所有线缆按配置图固定在端子插头上，用螺丝刀拧紧力矩为 $1.2 \pm 0.1 \text{ N} \cdot \text{m}$ 。Fix all the cables on the terminal plugs according to the configuration diagram and tighten them with a screwdriver at a torque of $1.2 \pm 0.1 \text{ N} \cdot \text{m}$.

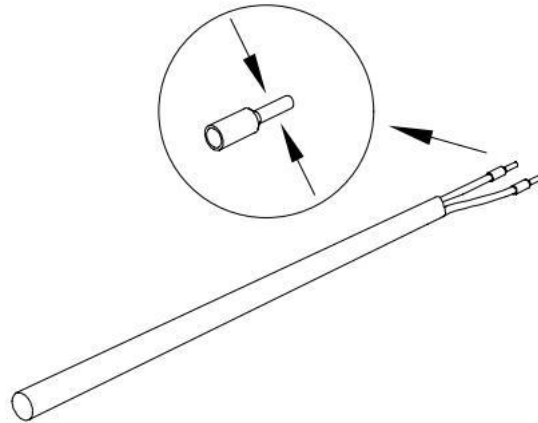

图 4.5.7-10

Figure 4.5.7-10

④ 向外拉线，检查是否安装牢固。将端子座插入连接器，直到发出咔嚓声。Pull the wire outward and check if it is installed firmly. Insert the terminal socket into the connector until a click is heard.

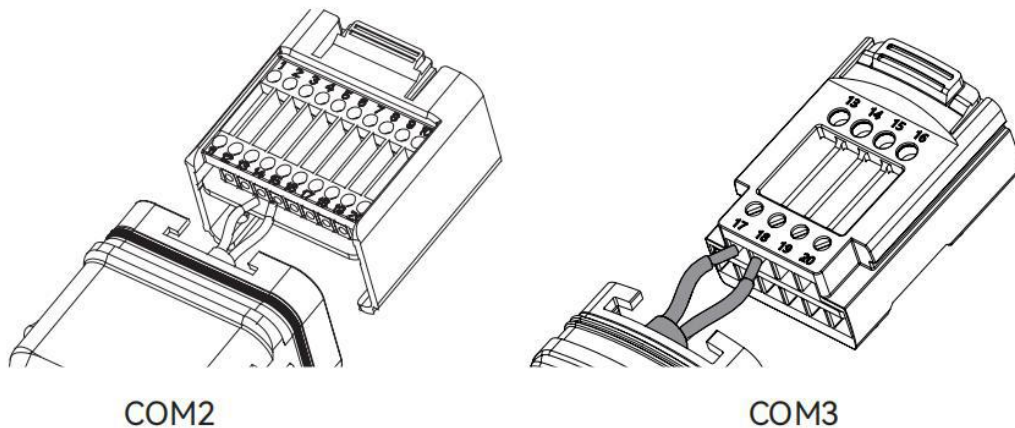

图 4.5.7-11

Figure 4.5.7-11

⑤ 拧紧旋转螺母。Tighten the rotating nut.

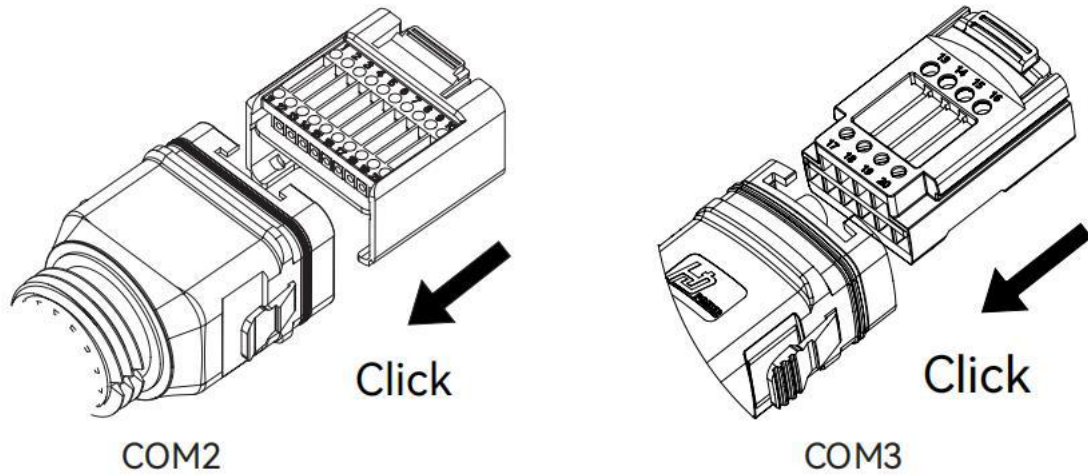

图 4.5.7-12

Figure 4.5.7-12

- 安装多功能 COM 接口
- Install the multi-functional COM interface

- ① 取下 COM 端子防水盖。Remove the waterproof cover of the COM terminal.
- ② 将 COM 连接器插入逆变器底部的 COM 端子，听到“咔”的一声即可。Insert the COM connector into the COM terminal at the bottom of the inverter until you hear a "click".

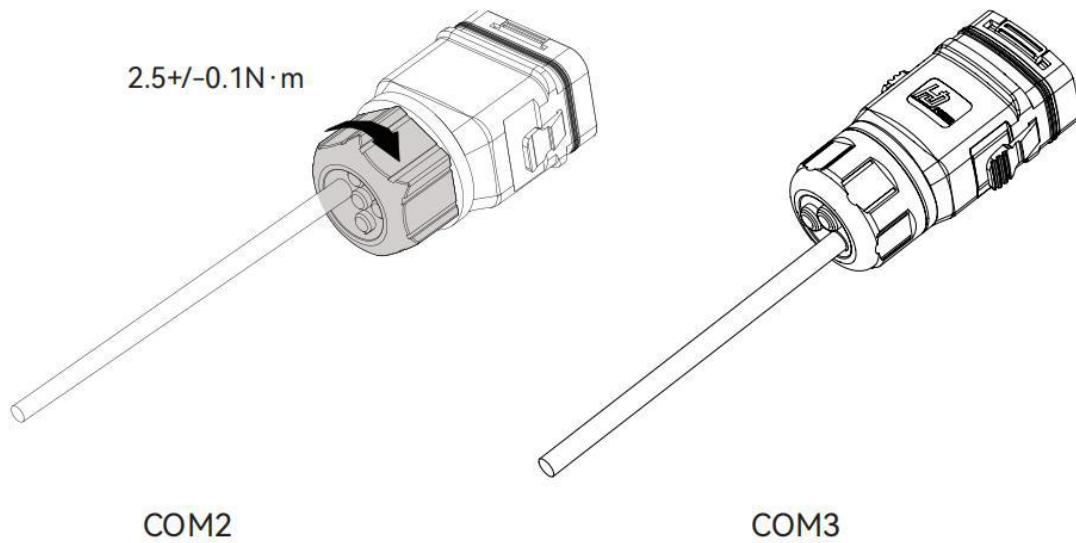

图 4.5.7-13

Figure 4.5.7-13

➤ 电表和 BMS 通信 Connect electricity meter with the BMS

RJ45 端子连接顺序及定义如下：

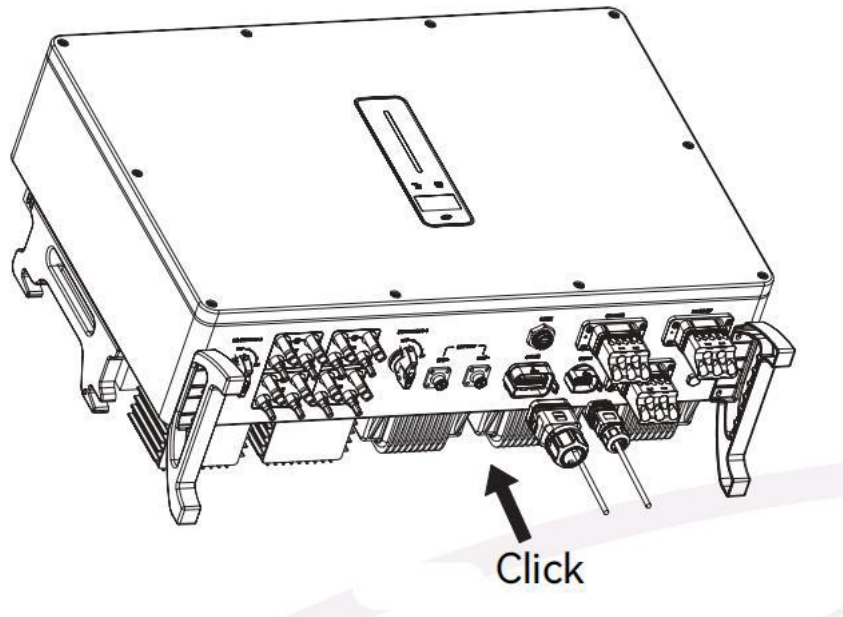
The connection sequence and definition of the RJ45 terminals are as follows:

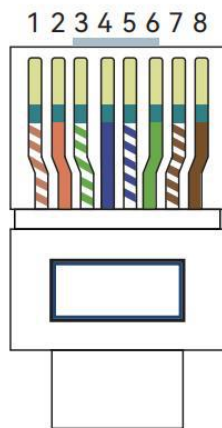

No.	Color	Meter Side	电池端
1	Orange & White	/	RS485_A3
2	Orange	/	RS485_B3
3	Green & White	RS485_B2	/
4	Blue	/	CANH_B
5	Blue & White	/	CANL_B
6	Green	RS485_A2	/
7	Brown & White	RS485_B2	/
8	Brown	RS485_A2	/

图 4.5.7-14 RJ45 端子连接顺序及定义

Figure 4.5.7-14 RJ45 terminal connection sequence and definition

➤ EMS 通讯，当通过 EMS 控制储能逆变器运行时，需要连接 EMS 通信线，EMS 与逆变器通信方式为 RS485。

➤ EMS communication: When controlling the operation of the energy storage inverter

through EMS, an EMS communication line needs to be connected. The communication mode between EMS and the inverter is RS485.

- DI ctrl, 逆变器同时只支持 DRM 和 Ripple Control 其中一种功能。
- DI ctrl. The inverter only supports one of the functions, DRM and Ripple Control, at the same time.

① DRM

根据澳大利亚和新西兰的安全法规，DRED (Demand Response Enabling Device) 接口是专门为其保留的。我们不为客户提供 DRED 设备。逆变器支持标准 AS/NZS 4777 中规定的“demand response modes”。逆变器集成了一个用于连接 DRED 的接线端子。According to relevant safety regulations, the DRED (Demand Response Enabling Device) interface is reserved specifically for it. We do not provide DRED equipment to customers. The inverter supports the “demand response modes” stipulated in the standard AS/NZS 4777. The inverter integrates a terminal block for connecting DRED.



图 4.5.7-15

Figure 4.5.7-15

！提示：在 15 (COM D/0) 和 16 (REF D/0) 端子之间有一个电阻，接线时不要拆卸该电阻。

！Hint: There is a resistor between terminals 15 (COM D/0) and 16 (REF D/0). Do not disassemble this resistor when wiring.

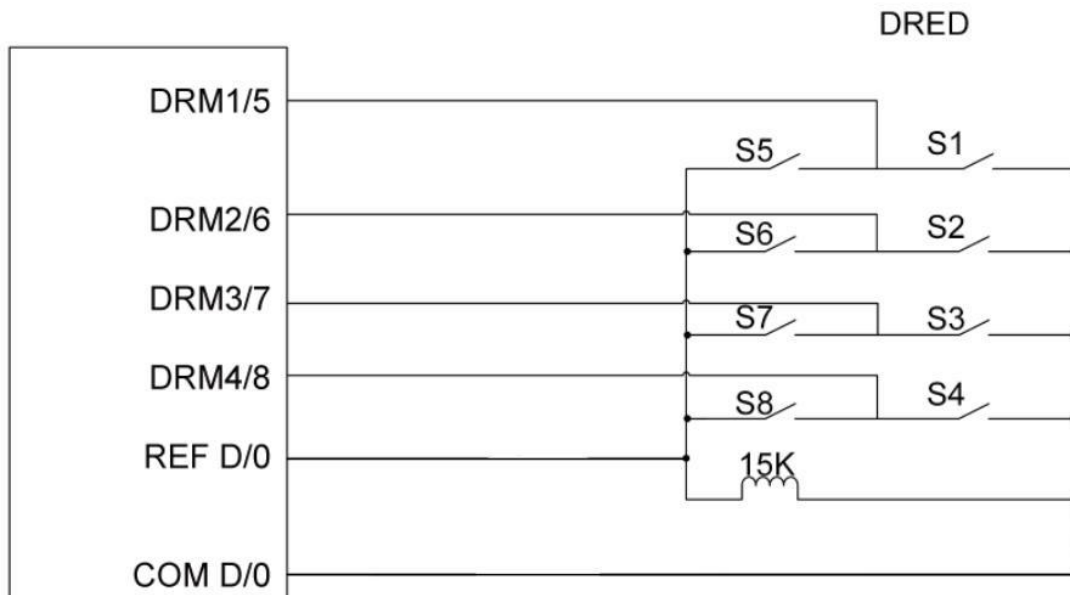
DRED mode as shown in table below:

Mode	Function
DRM 0	Operate the disconnection device
DRM 1	Do not consume power
DRM 2	Do not consume at more than 50% of rated power
DRM 3	Do not consume at more than 75% of rated power and source reactive power if capable
DRM 4	Increase power consumption (subject to constraints from other active DRMs)
DRM 5	Do not generate power
DRM 6	Do not generate at more than 50% of rated power
DRM 7	Do not generate at more than 75% of rated power and sink reactive power if capable.
DRM 8	Increase power generation (subject to constraints from other active DRMs)
Priority	DRM1 > DRM2 > DRM3 > DRM4
	DRM5 > DRM6 > DRM7 > DRM8

图 4.5.7-16

Figure 4.5.7-16

② RCR

根据德国和一些欧洲地区的安全规定，RCR（Ripple Control Receiver）接口是专门为其保留的，我们不为客户提供 RCR 设备。在德国和一些欧洲地区，Ripple Control Receive 用于将电网调度信号转换为干接点信号。干接点用于接收电网调度信号。

RCR 接线图（储能逆变器）如下：

According to the security regulations of the relevant regions, the RCR (Ripple Control Receiver) interface is reserved specifically for it, and we do not provide RCR devices to customers. In Germany and some European regions, Ripple Control Receive is used to convert power grid dispatching signals into dry contact signals. Dry contacts are used to receive power grid dispatching signals.

The RCR wiring diagram (energy storage inverter) is as follows:



图 4.5.7-17

Figure 4.5.7-17

RCR operation mode as shown in table below:

Switch mode (External RCR device)	Feed-in output power (in % of the Rated AC output power)
K1 turn on	0%
K2 turn on	30%
K3 turn on	60%
K4 turn on	100%
RCR priority: K1>K2>K3>K4	

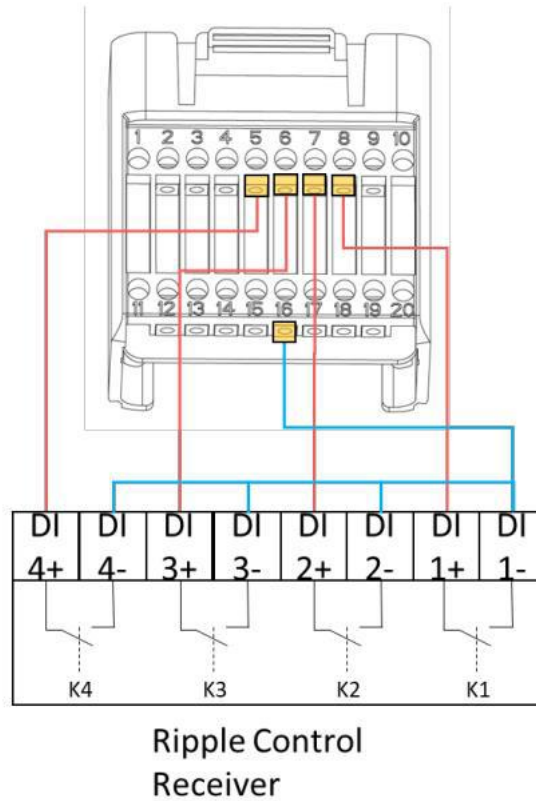
Figure 4.5.7-18

➤ 多功能继电器 Multifunctional relay

逆变器配有多功能干接点继电器，当连接外部的接触器时，可以帮助接通或关闭负载，或在连接柴油发电机启动信号时，可以帮助启动柴油发电机。

The inverter is equipped with a multi-functional dry contact relay. When connected to an external contactor, it can help turn on or off the load, or when connected

to a diesel generator start signal, it can help start the diesel generator.

! 提醒:

! Reminder:

DO 干接点最大电压和电流 :230VAC 1A/30 VDC 1A.

Maximum voltage and current of DO dry contact :230VAC 1A/ 30VDC 1A.

交流接触器应连接在逆变器和负载之间。

The AC contactor should be connected between the inverter and the load.

请勿将负载直接连接到 DO 端口。

DO not connect the load directly to the DO port.

接触器不由制造商提供的。将负载连接到 DO 端口, 如果负载设计有 DI 端口, 则直接使用逆变器的 DO 端口。

The contactor is not provided by the manufacturer. Connect the load to the DO port if the load is designed with DI.

当被控负载连接到 ON-GRID 侧时, 接触器线圈也必须连接到 ON-GRID 侧。

When the controlled load is connected to the ON-GRID side, the contactor coil must also be connected to the ON-GRID side.

当受控负载连接到 BACK-UP 侧时, 接触器线圈也必须连接到 BACK-UP 侧。

When the controlled load is connected to the BACK-UP side, the contactor coil must also be connected to the BACK-UP side.

负载控制:Load Control:



图 4.5.7-19 负载控制接线图

Figure 4.5.7-19 Load control wiring diagram

OLP 50kW/111kWh 风冷光储一体柜用户手册 OLP 50kW/111kWh Air Cooling Energy Storage Cabinet All-In-One Product User Manual	文件编号: OLP-EIB-V541_E111_P50-AO01-1001 Document number: OLP-EIB-V541_E111_P50-AO01-1001	版本: V0.1 Version:V0.1	Page 78 of 97
© 欧力普能源与自动化技术有限公司 2024 保留所有权利 © Olipower Energy & Automation Technologies 2024 All rights reserved.	地址: 深圳市光明区凤凰街道塘尾社区光明大道 380 号尚智科技园 2 栋 A 座 10 楼 Address: 10th Floor, Block A, Building 2, Shangzhi Science and Technology Park, No. 380 Guangming Avenue, Tangwei Community, Fenghuang Street, Guangming District, Shenzhen, China.		

- 发电机控制
- Generator control

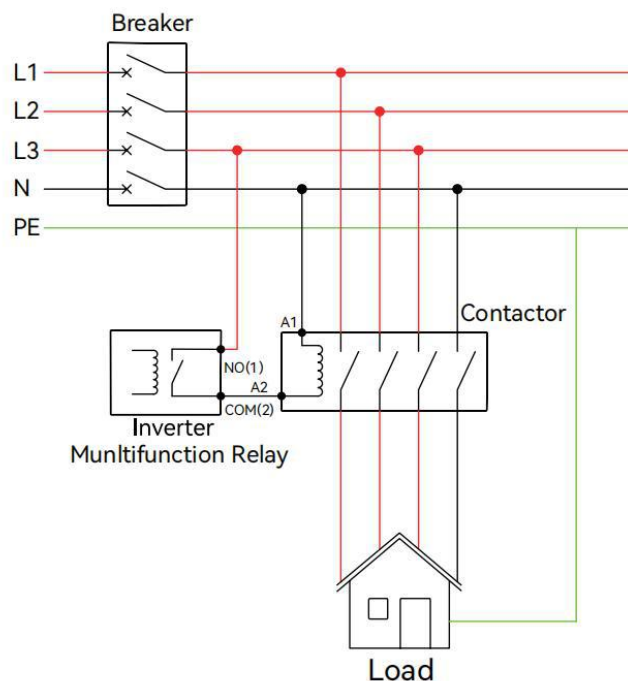
当“GEN 信号”激活时，开路触点 (GS) 将打开 (无电压输出)。

When the "GEN signal" is activated, the open contact (GS) will open (with no voltage output).

Inverter Multifunction Relay



图 4.5.7-20 发电机控制接线图

Figure 4.5.7-20 Generator control wiring diagram

4.5.8.PV 组串连接 PV String Connection

逆变器可能存在高压！

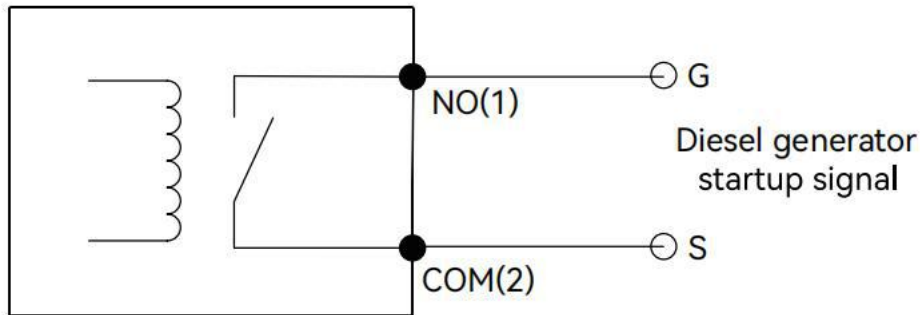
There may be high voltage in the inverter!

在进行电气操作前，请确保所有电缆无电压。

Before conducting electrical operations, please ensure that all cables are free of voltage.

在电气连接完成前，请勿连接直流开关和交流断路器。

Do not connect the DC switch and the AC circuit breaker until the electrical connection is completed.

为了更好的发电效率，请确保每个 MPPT 中连接相同型号和规格的光伏组件。

For better power generation efficiency, please ensure that each MPPT is connected with photovoltaic modules of the same model and specification.

PV 最大输入电压为 850V，超过 850V 逆变器将进入待机模式。

The maximum input voltage of PV is 850V. If it exceeds 850V, the inverter will enter standby mode.

- PV 侧要求
- Requirements on the PV side

<p>OLP 50kW/111kWh 风冷光储一体柜用户手册 OLP 50kW/111kWh Air Cooling Energy Storage Cabinet All-In-One Product User Manual</p>	<p>文件编号： OLP-EIB-V541_E111_P50-AO01-1001 Document number: OLP-EIB-V541_E111_P50-AO01-1001</p>	<p>版本：V0.1 Version:V0.1</p>	<p>Page 79 of 97</p>
<p>© 欧力普能源与自动化技术有限公司 2024 保留所有权利 © Olipower Energy & Automation Technologies 2024 All rights reserved.</p>	<p>地址：深圳市光明区凤凰街道塘尾社区光明大道 380 号尚智科技园 2 栋 A 座 10 楼 Address: 10th Floor, Block A, Building 2, Shangzhi Science and Technology Park, No. 380 Guangming Avenue, Tangwei Community, Fenghuang Street, Guangming District, Shenzhen, China.</p>		<p>Tel: +86 (755) 2650 8686 E-mail: sales@olipower.cn</p>

外接直流开关的系统图 System diagram of the external DC switch.

① 当地标准或法规可能要求光伏系统在直流侧配备外部直流开关。直流开关必须能够安全地断开光伏阵列的开路电压，再加上 20%的安全余量。在每个 PV 组串上安装直流开关，实现逆变器直流侧的隔离。

① Local standards or regulations may require that photovoltaic systems be equipped with external DC switches on the DC side. The DC switch must be capable of safely disconnecting the open-circuit voltage of the photovoltaic array, plus a 20% safety margin. Install a DC switch on each PV string to achieve isolation on the DC side of the inverter.



图 4.5.8-1

Figure 4.5.8-1

- 选择合适的 PV 线缆
- Select the appropriate PV cable.

Cable requirements		Cable stripping length
Outside diameter	Conductor core section	
5.9-8.8 mm	4 mm ²	7 mm

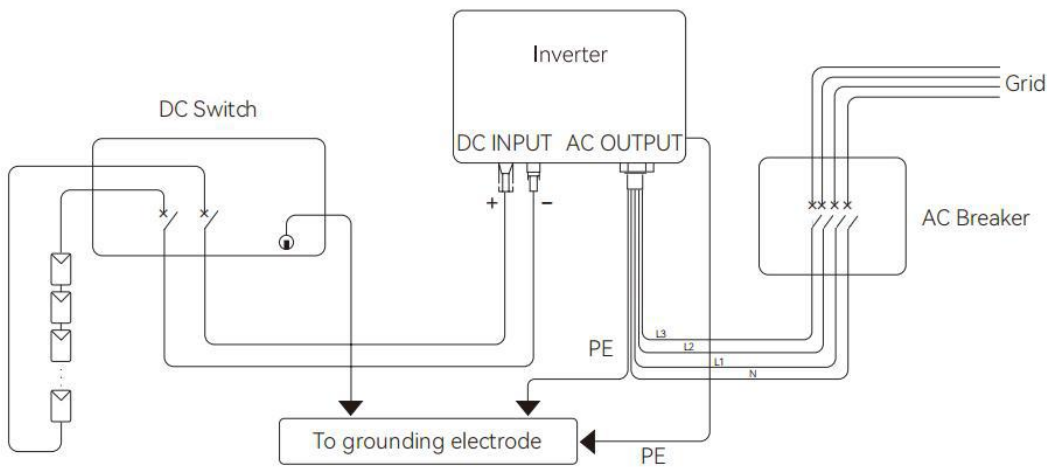
- 装配 PV 连接器，在装配 PV 连接器前，请确认线缆的极性正确。
- Before assembling the PV connector, please confirm that the polarity of the cable is correct.

① 将直流电缆绝缘套剥去 7mm。Peel off 7mm of the insulation sheath of the DC cable.



图 4.5.8-2

Figure 4.5.8-2

② 拆卸附件袋中的连接器。Remove the connector from the accessory bag.

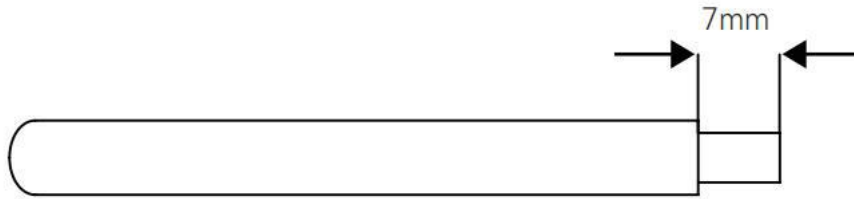

图 4.5.8-3

Figure 4.5.8-3

③ 将直流电缆通过直流接头螺母插入金属端子，用专业压接钳压接（用一定的力拉扯电缆，检查端子与电缆连接是否牢固）。Insert the DC cable into the metal terminal through the DC connector nut, and press it with a professional crimping pliers (pull the cable with a certain force to check if the terminal is firmly connected to the cable).

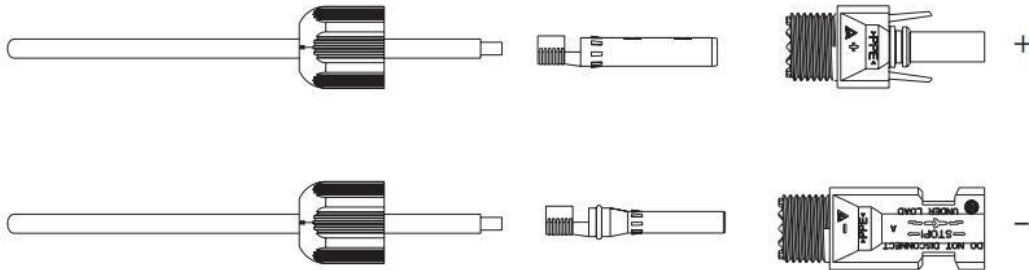

图 4.5.8-4

Figure 4.5.8-4

- ④ 将正负极线缆分别插入对应的正负极连接器中，将用一定力拉扯直流线缆，确保端子已紧紧插入连接器中。Insert the positive and negative cables into the corresponding positive and negative connectors respectively. Pull the DC cable with a certain force to ensure that the terminals are tightly inserted into the connectors.
- ⑤ 用扳手将螺母拧到末端，确保端子密封良好。Use a wrench to tighten the nut to the end to ensure that the terminal is well sealed.

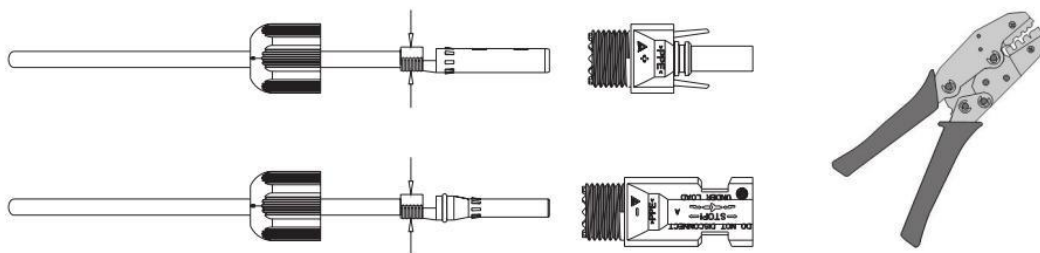

图 4.5.8-5

Figure 4.5.8-5

➤ 安装 PV 连接器 Install the PV connector.

- ① 将直流开关旋转到“OFF”位置。Rotate the DC switch to the “OFF” position.

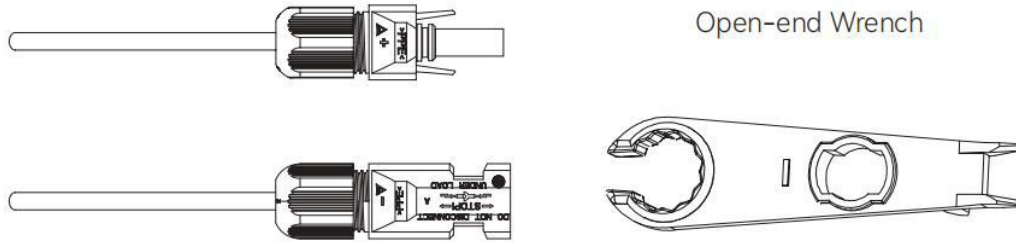

图 4.5.8-6

Figure 4.5.8-6

- ② 检查 PV 组串极性的正确，确保其开路电压在任何情况下都不超过逆变器输入限制 1000V，直流侧最大输入电压为 850V，超过 850V 逆变器将进入待机模式。Check the correct polarity of the PV string to ensure that its open-circuit voltage does not exceed

the inverter input limit of 1000V under any circumstances. The maximum input voltage on the DC side is 850V. If it exceeds 850V, the inverter will enter standby mode.

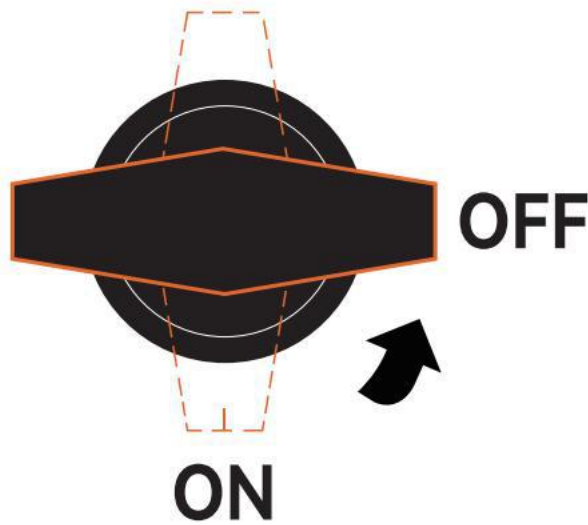

图 4.5.8-7

Figure 4.5.8-7

③ 将正负极连接器分别插入逆变器直流输入端子，听到“咔”的一声表示连接完成。Insert the positive and negative connectors into the DC input terminals of the inverter respectively. A "click" sound indicates that the connection is complete.

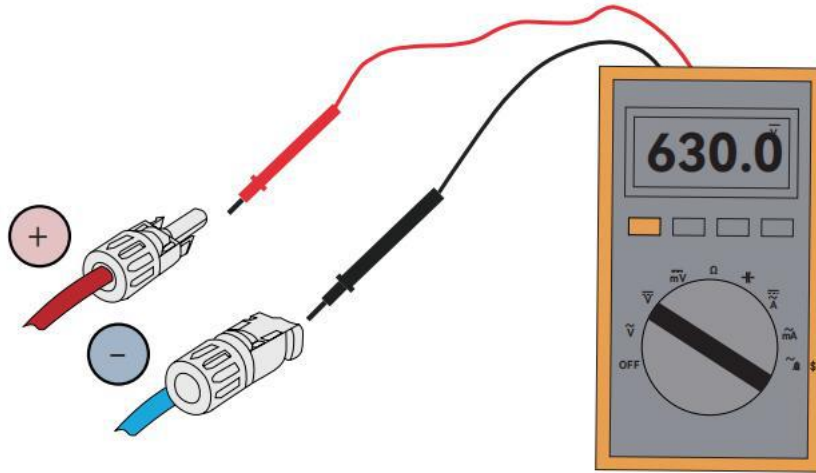

图 4.5.8-8

Figure 4.5.8-8

④ 将未使用到的 PV 端子用端子帽密封。Seal the unused PV terminals with terminal

caps.

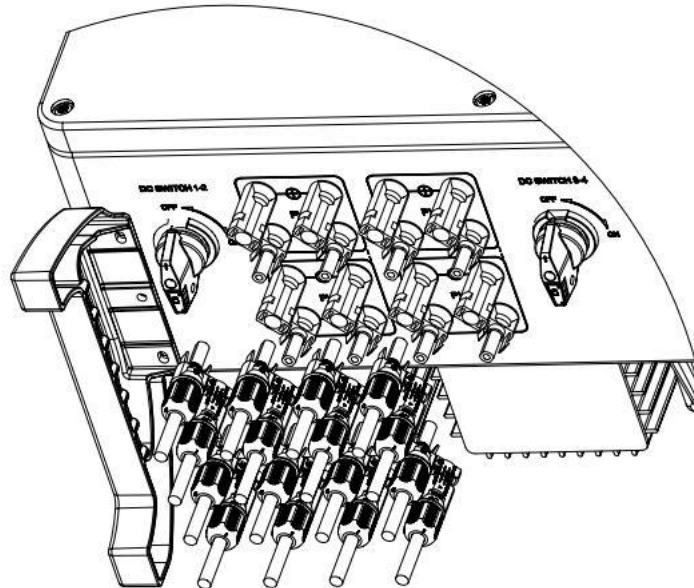
4.5.9. 电池电缆线连接 Battery Cables Connection

- 电池连接时必须考虑以下原则：
- The following principles must be considered when connecting the battery:
 - ①断开电网侧的交流断路器。
 - ①Disconnect the AC circuit breaker on the power grid side.
 - ②断开电池侧的断路器。
 - ②Disconnect the circuit breaker on the battery side.
 - ③将逆变器直流开关置于“OFF”位置。
 - ③Set the inverter DC switch to the “OFF” position.
 - ④确保电池最大输入电压在逆变器限制范围内。
 - ④Ensure that the maximum input voltage of the battery is within the limit range of the inverter.
- 选择合适的直流线缆
- Select the appropriate DC cable.

Cable requirements		Cable stripping length
Outside diameter	Conductor core section	
9.8±0.2 mm	25 mm ²	20 mm

图 4.5.9-1

Figure 4.5.9-1

- ①取出机柜内配套的线缆，将正极和负极连接器分别插入对应逆变器电池端子，“咔”声表示组装到位。
- ①Remove the cables that come with the cabinet, and insert the positive and negative connectors into the corresponding inverter battery terminals respectively. A “click” sound indicates that the assembly is in place.



图 4.5.9-2

Figure 4.5.9-2

②拔掉插头时，先按下开关按钮，再拔插头。

②When unplugging the plug, press the switch button first and then unplug the plug.

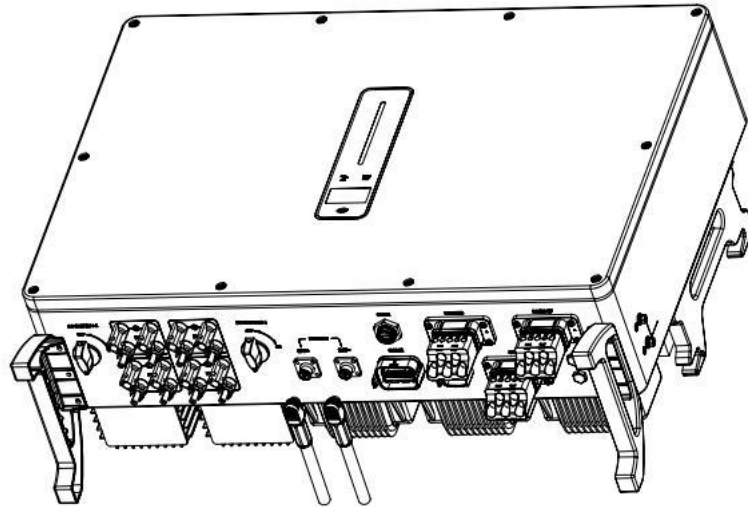

图 4.5.9-3

Figure 4.5.9-3

5. 调试与运行 Debugging And Operation

5.1. 检查 Inspection

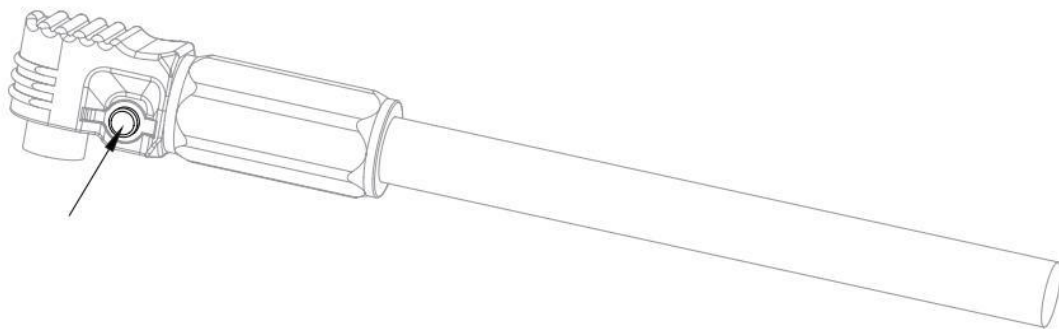
开机运行前需要检查以下项目：

Before starting up and running, the following items need to be checked:

<p>OLP 50kW/111kWh 风冷光储一体柜用户手册 OLP 50kW/111kWh Air Cooling Energy Storage Cabinet All-In-One Product User Manual</p>	<p>文件编号： OLP-EIB-V541_E111_P50-AO01-1001 Document number: OLP-EIB-V541_E111_P50-AO01-1001</p>	<p>版本：V0.1 Version:V0.1</p>	<p>Page 85 of 97</p>
<p>© 欧力普能源与自动化技术有限公司 2024 保留所有权利 © Olipower Energy & Automation Technologies 2024 All rights reserved.</p>	<p>地址：深圳市光明区凤凰街道塘尾社区光明大道 380 号尚智科技园 2 栋 A 座 10 楼 Address: 10th Floor, Block A, Building 2, Shangzhi Science and Technology Park, No. 380 Guangming Avenue, Tangwei Community, Fenghuang Street, Guangming District, Shenzhen, China.</p>		<p>Tel: +86 (755) 2650 8686 E-mail: sales@olipower.cn</p>

序号 NO.	开机运行前检查项目 Check items before startup and operation
1	检查柜内各个部分是否有凝露现象（表面有水膜或水滴产生）。若有，必须打开柜体通风，直到现象消失。 Check whether there is condensation phenomenon (water film or water droplets on the surface) in various parts of the cabinet. If there is, the cabinet must be opened for ventilation until the phenomenon disappears.
2	检查柜体各个通风口和散热风扇是否有异物阻塞。若有，必须清理干净堵塞风口的异物。 Check if there are any foreign objects blocking the ventilation openings and cooling fans of the cabinet. If there are any foreign objects blocking the air vent, they must be cleaned up.
3	与电网连接侧端子必须正确连接并牢固，确保电压在规定范围内，不存在短路等故障。 The terminal on the side connected to the power grid must be correctly connected and firmly secured to ensure that the voltage is within the specified range and there are no faults such as short circuits.
4	各个控制信号电缆接线正确。 The wiring of each control signal cable is correct.
5	柜内与各个电源回路连接点无异物。（电线头、金属屑等） There are no foreign objects at the connection points between the cabinet and various power circuits. (Wire heads, metal shavings, etc.)
6	柜体必须可靠接地。 The cabinet must be reliably grounded.

表 5.1 开机运行前检查表

Table 5.1 Pre startup Inspection Checklist

5.2. 操作说明 Operating Instructions

5.2.1. 开机 Startup

在开机前的检查无误后，按顺序执行开机操作：

After confirming the correctness of the pre boot check, perform the boot operation in sequence:

- 1) 确认电缆按要求连接好；

Confirm that the cable has been connected as required;

<p>OLP 50kW/111kWh 风冷光储一体柜用户手册 OLP 50kW/111kWh Air Cooling Energy Storage Cabinet All-In-One Product User Manual</p>	<p>文件编号： OLP-EIB-V541_E111_P50-AO01-1001 Document number: OLP-EIB-V541_E111_P50-AO01-1001</p>	<p>版本：V0.1 Version:V0.1</p>	<p>Page 86 of 97</p>
<p>© 欧力普能源与自动化技术有限公司 2024 保留所有权利 © Olipower Energy & Automation Technologies 2024 All rights reserved.</p>	<p>地址：深圳市光明区凤凰街道塘尾社区光明大道 380 号尚智科技园 2 栋 A 座 10 楼 Address: 10th Floor, Block A, Building 2, Shangzhi Science and Technology Park, No. 380 Guangming Avenue, Tangwei Community, Fenghuang Street, Guangming District, Shenzhen, China.</p>		<p>Tel: +86 (755) 2650 8686 E-mail: sales@olipower.cn</p>

2) 闭合高压控制箱-隔离开关 Q01;

Close the high-voltage control box - disconnecter Q01;

3) 闭合柜内空调电源断路器 Q02;

Close the power circuit breaker Q02 of the air conditioner inside the cabinet;

4) 高压控制箱上 RUN 灯 (绿色) 常亮;

The RUN light (green) on the high-voltage control box is always on;

5) 开机完成。

Power on completed.

5.2.2. 逆变器监控配置 Inverter Monitoring Setting

➤ 检查及操作

➤ Inspection and Manufacturing

➤ 检查清单:

➤ Inspection list:

① 电池与逆变器 CAN 接线。

CAN connection between the battery and the inverter.

② 逆变器和电池的接地接线。

Ground wire connection between the inverter and the battery.

③ 通讯模块插入。

Insert the communication module.

④ 多功能接口插入。

Multi-functional interface insertion.

⑤ 智能电表接线与供电。

Wiring and power supply of smart electricity meters.

➤ 操作顺序:

➤ Setting Priority:

① 交流端保险闭合 (如有)。

The fuse at the AC terminal is closed (if any).

② 交流断路器闭合。

The AC circuit breaker is closed.

③ 电池直流开关闭合。

The DC switch of the battery is closed.

④ 电池开机按钮。

Battery power button.

⑤ 打开逆变器光伏直流开关。

Turn on the photovoltaic DC switch of the inverter.

➤ 如一切就绪, 请用手机扫描下图二维码下载 MetaEss APP.

<p>OLP 50kW/111kWh 风冷光储一体柜用户手册 OLP 50kW/111kWh Air Cooling Energy Storage Cabinet All-In-One Product User Manual</p>	<p>文件编号: OLP-EIB-V541_E111_P50-AO01-1001 Document number: OLP-EIB-V541_E111_P50-AO01-1001</p>	<p>版本: V0.1 Version:V0.1</p>	<p>Page 87 of 97</p>
--	---	----------------------------------	----------------------

- If everything is ready, please scan the QR code below with your mobile phone to download the MetaEss APP.



V4.0.7-(3)

- 下载 MetaEss APP 完成后，打开 APP 主界面（如下图）
- After downloading the MetaEss APP, open the main interface of the APP (as shown in the following figure).
 - ① 左上角选择对应的语言。Select the corresponding language in the upper left corner.

② 点击设备直连。Click on Direct connection of the device.

③ 搜索设备连接逆变器 WiFi，使用移动设备检索逆变器 WiFi，检索名为 WIFI-APXXXXXX 的 WiFi，其名称最后几位同逆变器 SN 码相同。操作前请确保 WiFi 棒或者二合一模块已连接至逆变器。连接后返回 MetaEss APP 并点击设备直连，使用安装者角色登入，（默认密码：123456）。

Search for the device to connect to the inverter's WiFi. Use a mobile device to search for the inverter's WiFi. Search for a WIFI named Wifi-apxxxxxx, whose last few digits are the same as the inverter's SN code. Please ensure that the WiFi stick or the 2-in-1 module is connected to the inverter before operation. After connecting, return to the MetaEss APP and click on Device Direct Connection. Log in using the

<p>OLP 50kW/111kWh 风冷光储一体柜用户手册 OLP 50kW/111kWh Air Cooling Energy Storage Cabinet All-In-One Product User Manual</p>	<p>文件编号： OLP-EIB-V541_E111_P50-AO01-1001 Document number: OLP-EIB-V541_E111_P50-AO01-1001</p>	<p>版本: V0.1 Version:V0.1</p>	<p>Page 88 of 97</p>
<p>© 欧力普能源与自动化技术有限公司 2024 保留所有权利 © Olipower Energy & Automation Technologies 2024 All rights reserved.</p>	<p>地址: 深圳市光明区凤凰街道塘尾社区光明大道 380 号尚智科技园 2 栋 A 座 10 楼 Address: 10th Floor, Block A, Building 2, Shangzhi Science and Technology Park, No. 380 Guangming Avenue, Tangwei Community, Fenghuang Street, Guangming District, Shenzhen, China. Tel: +86 (755) 2650 8686 E-mail: sales@olipower.cn</p>		

installer role (default password: 123456).

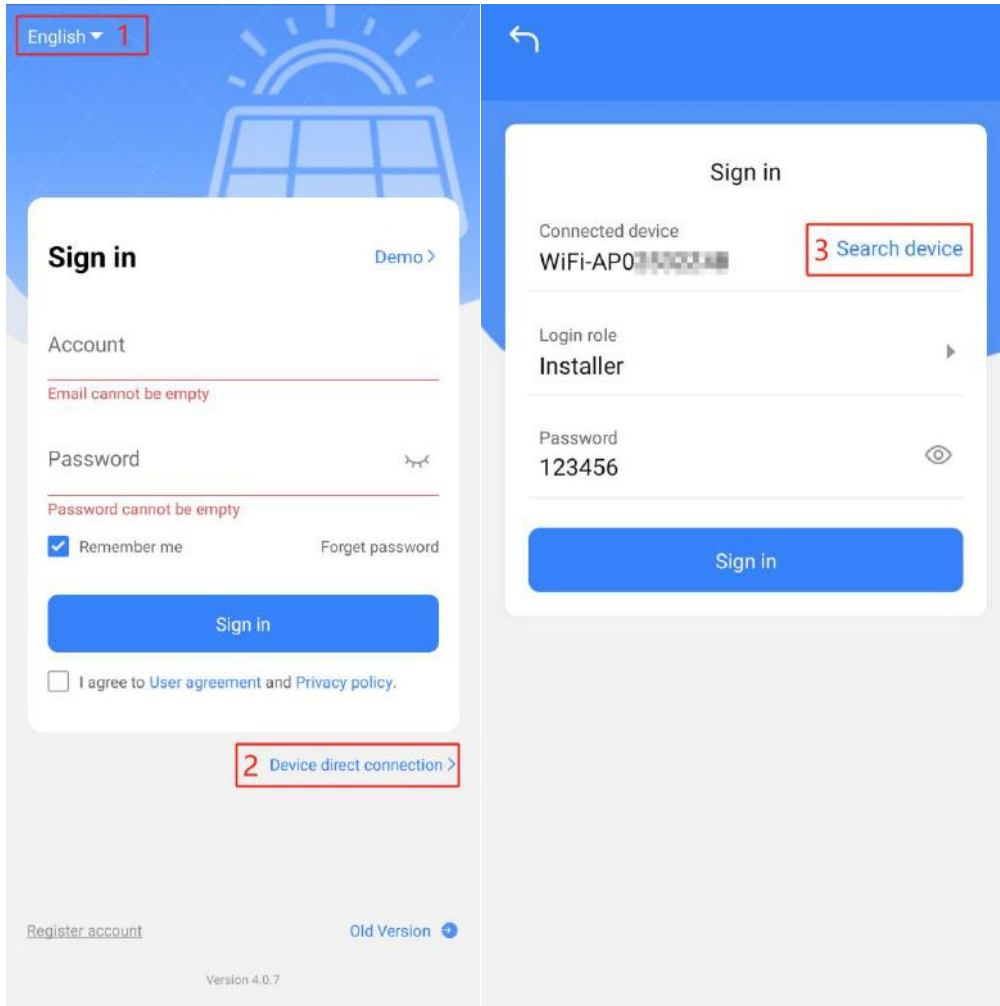

- 快速配置和 WiFi（如下图）
- Quick configuration and WiFi (as shown in the following figure).
 - ① 根据快速配置步骤完成逆变器参数设置
Complete the inverter parameter Settings according to the quick configuration steps.
 - ② 将逆变器连接至客户 WiFi（连接时请断开移动数据）
Connect the inverter to the customer's WiFi (please disconnect the mobile data when connecting).
- 创建电站和账户
- Create power stations and accounts.
 - ① 登入你的组织账户（请从你的上级组织处获取账户。）
Log in to your organization account (please obtain the account from your superior organization).

<p>OLP 50kW/111kWh 风冷光储一体柜用户手册 OLP 50kW/111kWh Air Cooling Energy Storage Cabinet All-In-One Product User Manual</p> <p><small>© 欧力普能源与自动化技术有限公司 2024 保留所有权利 © Olipower Energy & Automation Technologies 2024 All rights reserved.</small></p>	<p>文件编号： OLP-EIB-V541_E111_P50-AO01-1001 Document number: OLP-EIB-V541_E111_P50-AO01-1001</p> <p><small>地址：深圳市光明区凤凰街道塘尾社区光明大道 380 号尚智科技园 2 栋 A 座 10 楼 Address: 10th Floor, Block A, Building 2, Shangzhi Science and Technology Park, No. 380 Guangming Avenue, Tangwei Community, Fenghuang Street, Guangming District, Shenzhen, China.</small></p>	<p>版本：V0.1 Version:V0.1</p>	<p>Page 89 of 97</p> <p><small>Tel: +86 (755) 2650 8686 E-mail: sales@olipower.cn</small></p>
--	---	---------------------------------	---

② 使用客户信息创建电站 (客户账户及密码将发送至你填入的邮箱中。)

Create a power station using customer information (the customer account and password will be sent to the email address you filled in).

③ 添加逆变器至该电站 (SN 码及校验码见铭牌。)

Add an inverter to this power station (the SN code and check code are indicated on the nameplate).

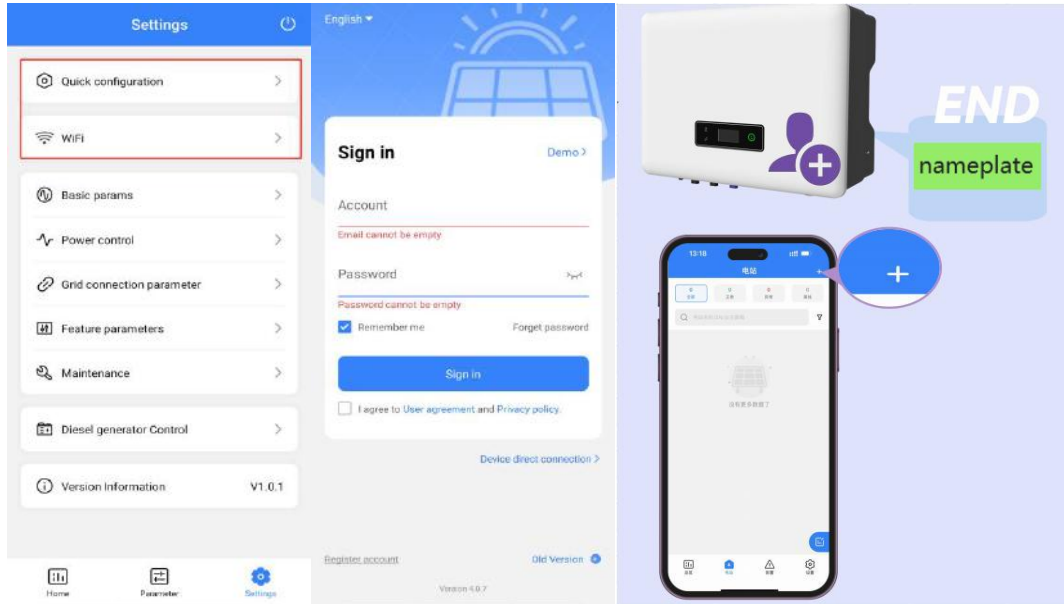

5.2.3. 关机 Shutdown

确认可以关机后，按顺序执行关机操作：

After confirming that the shutdown is possible, perform the shutdown operation in sequence:

- 1) 确认功率输出停止；
Confirm that the power output has stopped;
- 2) 断开柜内空调电源断路器 Q02；
- 3) 断开高压控制箱-隔离开关 Q01；
Disconnect the high-voltage control box - isolation switch Q01;
- 4) 关机完成。
Shutdown completed.

<p>OLP 50kW/111kWh 风冷光储一体柜用户手册 OLP 50kW/111kWh Air Cooling Energy Storage Cabinet All-In-One Product User Manual</p>	<p>文件编号： OLP-EIB-V541_E111_P50-AO01-1001 Document number: OLP-EIB-V541_E111_P50-AO01-1001</p>	<p>版本：V0.1 Version:V0.1</p>	<p>Page 90 of 97</p>
<p>© 欧力普能源与自动化技术有限公司 2024 保留所有权利 © Olipower Energy & Automation Technologies 2024 All rights reserved.</p>	<p>地址：深圳市光明区凤凰街道塘尾社区光明大道 380 号尚智科技园 2 栋 A 座 10 楼 Address: 10th Floor, Block A, Building 2, Shangzhi Science and Technology Park, No. 380 Guangming Avenue, Tangwei Community, Fenghuang Street, Guangming District, Shenzhen, China.</p>		<p>Tel: +86 (755) 2650 8686 E-mail: sales@olipower.cn</p>

6. 故障处理 Fault Handling



注意安全 Caution!

在自检时请不要拆卸机器部件。

Please do not disassemble machine components during self inspection.

6.1.故障一览表 Fault List

序号 NO.	故障名称 Fault name	可能原因 Possible reasons	故障处理 Fault handling
1	电池单体过压故障 Overvoltage fault of battery cell	1. BMS 故障 BMS malfunction 2. 电压采集点故障 Voltage collection point malfunction 3. 过度充 Overcharging	1. 更换 BMS Replace BMS 2. 检查电压采集点 Check the voltage collection point 3. 停止充电 Stop charging
2	电池单体欠压故障 Undervoltage fault of battery cell	1. BMS 故障 BMS malfunction 2. 电压采集点故障 Voltage collection point malfunction 3. 长期不充电 Long term non charging	1. 更换 BMS Replace BMS 2. 检查电压采集点 Check the voltage collection point 3. 及时充电 Charge in a timely manner
3	电池总电压过压故障 Battery total voltage overvoltage fault	过度充电 Overcharging	停止充电，检查逆变器 Stop charging, Check the inverter
4	电池总电压欠压故障 Battery total voltage undervoltage fault	长期不充电 Long term non charging	及时充电，检查逆变器 Charge in a timely, Check the inverter manner
5	电池充电高温故障 High temperature fault during	1. BMS 故障 BMS malfunction 2. 温度采集点故障	1. 更换 BMS Replace BMS 2. 检查温度采集点

OLP 50kW/111kWh Air Cooling Energy Storage Cabinet All-In-One

	battery charging	Temperature collection point malfunction 3. 空调异常 Air Conditioning Abnormal	Check the Temperature collection point 3. 检查空调线束, 重启空调 Check the air conditioner wiring harness and restart the air conditioner
6	电池充电低温故障 Low temperature fault during battery charging	1. BMS 故障 BMS malfunction 2. 温度采集点故障 Temperature collection point malfunction 3. 空调异常 Air Conditioning Abnormal	1. 更换 BMS Replace BMS 2. 检查温度采集点 Check the Temperature collection point 3. 检查空调线束, 重启空调 Check the air conditioner wiring harness and restart the air conditioner
7	电池放电高温故障 High temperature fault during battery discharge	1. BMS 故障 BMS malfunction 2. 温度采集点故障 Temperature collection point malfunction 3. 空调异常 Air Conditioning Abnormal	1. 更换 BMS Replace BMS 2. 检查温度采集点 Check the Temperature collection point 3. 检查空调线束, 重启空调 Check the air conditioner wiring harness and restart the air conditioner
8	电池放电低温故障 Low temperature fault during battery discharge	1. BMS 故障 BMS malfunction 2. 温度采集点故障 Temperature collection point malfunction 3. 空调异常 Air Conditioning Abnormal	1. 更换 BMS Replace BMS 2. 检查温度采集点 Check the Temperature collection point 3. 检查空调线束, 重启空调 Check the air conditioner wiring harness and restart the air conditioner
9	电池充电过流故障 Battery charging	充电电流超过电池最大电流 Charging current	降低充电功率 Reduce charging power

OLP 50kW/111kWh 风冷光储一体柜用户手册 OLP 50kW/111kWh Air Cooling Energy Storage Cabinet All-In-One Product User Manual	文件编号: OLP-EIB-V541_E111_P50-AO01-1001 Document number: OLP-EIB-V541_E111_P50-AO01-1001	版本: V0.1 Version:V0.1	Page 92 of 97
--	---	--------------------------	---------------

OLP 50kW/111kWh Air Cooling Energy Storage Cabinet All-In-One

	overcurrent fault	exceeds the maximum current of the battery	
10	电池放电过流故障 Battery discharge overcurrent fault	放电电流超过电池最大电流 Discharge current exceeds the maximum current of the battery	降低放电功率 Reduce discharge power
11	绝缘低故障 Low insulation fault	1. 未接地 Not grounded 2. 雨水或液体进入设备 Rainwater or liquids entering the equipment	1. 检查接地回路是否安装正确 Check if the grounding circuit is installed correctly 2. 检查设备是否淋湿 Check if the equipment is wet
12	SOC 过低告警 SOC low alarm	电量过低 Low battery level	充电处理 Charging processing
13	空调通讯故障 Air conditioner communication failure	BMS 与空调通讯线断开 BMS and air conditioner communication line disconnected	检查 BMS 与空调通讯线 Check the communication line between BMS and air conditioner
14	消防触发 Fire trigger	温度感应器和烟雾感应器同时触发, 灭火装置启动 The temperature sensor and smoke sensor are triggered simultaneously, and the fire extinguishing device is activated	联系厂家 Contact the manufacturer
15	BMS 通讯故障 BMS communication failure	1. BMS 故障 BMS malfunction 2. BMS 通讯线断开 BMS communication line disconnected	1. 更换 BMS Replace BMS 2. 检查 BMS 通讯线 Check the BMS communication cable
16	急停触发 Emergency stop triggered	检查急停功能接线 Check the wiring of the emergency stop function	检查储能柜, 无故障后, 人工恢复 Check the energy storage cabinet and restore it manually after no faults

			are found
--	--	--	-----------

表 6.1 故障一览表

Table 6.1 Fault List

7. 日常保养与维护 Daily Maintenance And Upkeep

由于环境的温度、湿度、粉尘及振动的影响，会导致储能柜内部的器件老化，有可能引起潜在的故障发生或降低了机柜的使用寿命。因此，有必要对储能柜实施日常和定期的维护保养工作。

Due to the influence of temperature, humidity, dust, and vibration in the environment, the components inside the energy storage cabinet may age, which may cause potential failures or reduce the service life of the cabinet. Therefore, it is necessary to carry out daily and regular maintenance work on the energy storage cabinet

注意安全 Caution!

- 需具有专业资格的人员才可以对储能柜进行维护。
- Personnel with professional qualifications are required to maintain the energy storage cabinet.
- 机柜中带强电，在开始维护前必须进行必要的安全防范措施。
- The cabinet is equipped with strong electricity, and necessary safety precautions must be taken before starting maintenance.
- 维护前，必须保证电源都已经断开。
- Before maintenance, it is necessary to ensure that all power sources have been disconnected.
- 维护中，必须严格遵循正确的操作规程。
- During maintenance, it is necessary to strictly follow the correct operating procedures.
- 储能柜内部有储能电容，下电后必须等待 20 分钟以上确认变流器内部处于无电状态才可以进行维护。
- There are energy storage capacitors inside the energy storage cabinet. After power off, it is necessary to wait for more than 20 minutes to confirm that the inverter is in a dead state before maintenance can be carried out.
- 电源断开后，需在断开处挂警示标志，防止在维护过程中有人上电。
- After the power is disconnected, a warning sign should be hung at the disconnection location to prevent someone from powering on during maintenance.
- 为避免意外危险，在维护过程中，维护人员应穿戴绝缘防护用品。

<p>OLP 50kW/111kWh 风冷光储一体柜用户手册 OLP 50kW/111kWh Air Cooling Energy Storage Cabinet All-In-One Product User Manual</p>	<p>文件编号： OLP-EIB-V541_E111_P50-AO01-1001 Document number: OLP-EIB-V541_E111_P50-AO01-1001</p>	<p>版本: V0.1 Version:V0.1</p>	<p>Page 94 of 97</p>
<p>© 欧力普能源与自动化技术有限公司 2024 保留所有权利 © Olipower Energy & Automation Technologies 2024 All rights reserved.</p>	<p>地址：深圳市光明区凤凰街道塘尾社区光明大道 380 号尚智科技园 2 栋 A 座 10 楼 Address: 10th Floor, Block A, Building 2, Shangzhi Science and Technology Park, No. 380 Guangming Avenue, Tangwei Community, Fenghuang Street, Guangming District, Shenzhen, China.</p>		<p>Tel: +86 (755) 2650 8686 E-mail: sales@olipower.cn</p>

- To avoid accidental danger, maintenance personnel should wear insulation protective equipment during the maintenance process.

7.1. 日常检查项目 Daily Inspection Items

日常检查项目按照下列要点实施：

Daily inspection items should be implemented according to the following key points:

序号 NO.	日常检查项目 Daily inspection items	备注 Remarks
1	需对储能柜的输入、输出电压电流以及运行状态进行实时监控，并定人定点观察，发现工作异常或电压电流异常需及时进行维护。 Real time monitoring of the input, output voltage, current, and operating status of the energy storage cabinet is required, Assign personnel to observe at designated locations, and promptly carry out maintenance if any abnormal work or voltage/current is found.	
2	储能柜机柜内部有无异常响声。 Is there any abnormal noise inside the energy storage cabinet.	
3	储能柜机柜内部有无异味。 Is there any odor inside the energy storage cabinet.	
4	通过屏幕显示的内部温度，观察温度在正常范围内。 Observe the temperature within the normal range based on the internal temperature displayed on the screen.	
5	检查机箱外观表面无受损，对表面脏污处使用水或酒精清理，对表面油漆受损处进行补漆处理。 Check the exterior surface of the chassis for any damage, clean any dirty areas with water or alcohol, and touch up any damaged paint on the surface.	

表 7.1 日常检查项目表

Table 7.1 List of Daily Inspection Items

注意：建议每周检查一次

Attention: It is recommended to check once a week

7.2. 定期检查项目 Regular Inspection Items

定期检查主要针对日常检查及日常运行过程中难以检查到的地方：

OLP 50kW/111kWh 风冷光储一体柜用户手册 OLP 50kW/111kWh Air Cooling Energy Storage Cabinet All-In-One Product User Manual	文件编号： OLP-EIB-V541_E111_P50-AO01-1001 Document number: OLP-EIB-V541_E111_P50-AO01-1001	版本：V0.1 Version:V0.1	Page 95 of 97
© 欧力普能源与自动化技术有限公司 2024 保留所有权利 © Olipower Energy & Automation Technologies 2024 All rights reserved.	地址：深圳市光明区凤凰街道塘尾社区光明大道 380 号尚智科技园 2 栋 A 座 10 楼 Address: 10th Floor, Block A, Building 2, Shangzhi Science and Technology Park, No. 380 Guangming Avenue, Tangwei Community, Fenghuang Street, Guangming District, Shenzhen, China.		Tel: +86 (755) 2650 8686 E-mail: sales@olipower.cn

OLP 50kW/111kWh Air Cooling Energy Storage Cabinet All-In-One

Regular inspections mainly target areas that are difficult to detect during daily inspections and operations:

序号 NO.	定期检查项目 Regular inspection items	备注 Remarks
1	检查储能柜外观无破损、生锈。 Check the appearance of the energy storage cabinet for any damage or rust.	
2	用测温仪器检测设备内部温度无异常。 Use a temperature measuring instrument to check the internal temperature of the equipment without any abnormalities.	
3	检查设备周围的通风、环境温度、湿度、灰尘等环境满足要求。 Check that the ventilation, ambient temperature, humidity, dust, and other environmental conditions around the equipment meet the requirements.	
4	检查线缆无缘层老化、破损等现象，若出现需增加相应的绝缘措施或更换线缆。 Check for any signs of aging or damage to the cable insulation layer. If any issues arise, additional insulation measures should be taken or the cable should be replaced.	
5	检查接线螺栓处无老化、烧焦的痕迹，并用手晃动，确认处于拧紧的状态。 Check that there are no signs of aging or burning at the wiring bolts, and shake them by hand to confirm that they are tightened.	

表 7.2 定期检查项目表

Table 7.2 Regular Inspection Item List

注意：建议每三个月检查一次

Attention: It is recommended to check every three months

8. 设备清单 Equipment List

序号 No.	名称 Name	说明 Description	数量 QTY	单位 Unit	备注 Note
1	机柜 Cabinet	尺寸 Dimension: 700*1300*2200mm (W*D*H)	1	台 pcs	
2	光储混合逆变器 Hybrid Battery Inverter	50kW, 50/60Hz, 3L/N/PE, 220/380V, 230/400V	1	台 pcs	
3	高压控制箱	BMU+高压保护	1	台	

OLP 50kW/111kWh 风冷光储一体柜用户手册 OLP 50kW/111kWh Air Cooling Energy Storage Cabinet All-In-One Product User Manual	文件编号: OLP-EIB-V541_E111_P50-AO01-1001 Document number: OLP-EIB-V541_E111_P50-AO01-1001	版本: V0.1 Version: V0.1	Page 96 of 97
--	---	---------------------------	---------------

OLP 50kW/111kWh Air Cooling Energy Storage Cabinet All-In-One

	High voltage control box	BMU + High voltage protection		pcs	
4	风冷电池包 Air-cooled battery packs	76.8V/15.8kWh	7	台 pcs	
5	热管理系统 Thermal management system	工业空调 Industrial air conditioners	1	套 pcs	
6	消防系统 Fire Supression System	温感+烟感+气溶胶 Heat Detector + Smoke Detector + Aerosol	1	套 pcs	
7	水浸报警系统 Waterlogging alarm system	水浸传感器+控制器 Waterlogging Sensor + Controller	1	套 pcs	
8	设备配件 equipment accessories	线缆走线槽+防逆流电表+电池电缆+通讯线 Cable trough, anti-backcurrent meter, battery cable, communication cable	1	套 pcs	

表 8 设备清单

Table 8 Equipment List

注意：配件不包含电缆。

Attention: The accessories do not include cables.

OLP 50kW/111kWh 风冷光储一体柜用户手册 OLP 50kW/111kWh Air Cooling Energy Storage Cabinet All-In-One Product User Manual	文件编号： OLP-EIB-V541_E111_P50-AO01-1001 Document number: OLP-EIB-V541_E111_P50-AO01-1001	版本：V0.1 Version:V0.1	Page 97 of 97
--	---	-------------------------	---------------