



# OLP-EIB 125kW/261kWh

## Liquid-Cooled Energy Storage Integrated Cabinet

The OLP-EIB series energy storage integrated cabinets are meticulously developed by OLiPower, which is experienced in power electronics, automation, IoT, and AI technologies. The OLP-EIB are on grid energy storage products designed for C&I, EV charging station, public buildings and so on. They have functions like peak shaving, peak & frequency regulation, transformer expansion, and smoothing renewable energy fluctuations, providing users with safe, reliable, economical, and efficient green electricity.



### PRODUCT FEATURES

#### Extreme Safety

- Self-developed BMS, EMS, and cloud platform to achieve three-level electrical protection of "Pack - Cluster - Cabinet".  
Comprehensive fire detection and multiple fire protection.
- The entire cabinet and each battery pack, detected by combustible gas, smoke and temperature sensor, are equipped with perfluorohexanone fire extinguishing system and water sprinkler system.

#### Intelligent & Efficient Operation

- Designed with high energy density to save more space.
- The annual availability rate is  $\geq 95\%$ , and the comprehensive cycle efficiency is  $\geq 90\%$ .
- The cell life is up to 10 years and 8000 cycles.
- The intelligent liquid - cooled temperature control system can control the temperature difference of battery cells within  $3^{\circ}\text{C}$ , which greatly slows down the capacity attenuation.

#### Flexible Deployment

- Support to be installed by hoisting and forklift, and available for side-by-side and back-to-back deployment.  
Flexible capacity expansion, up to 1.25MW/2.61MWh,
- with 10 systems operating in parallel.  
Pre-installation and commissioning in the factory,
- plug-and-play on-site.

#### Smart Maintenance

- Providing the function of demand control, anti-backflow and transformer overload protection to make the on-grid operating safely.
- Providing all-time cloud monitoring, remote configuration, and OTA to keep the system in the best condition.
- Automatically generate daily/ monthly operation reports.

# TECHNICAL PARAMETER

Model	OLP-EIB-V832_E261_P125-LO	
Battery System	Cell Type	LFP
	Cell Parameter	3.2V/314Ah
	Cell Configuration	1P260S
	Rated Energy	261kWh
	Rated Voltage	832V
	Voltage Range	728 ~ 949V
	Rated Current	157A
	Max. Current	200A
On-grid	Rated Power	125kW
	Rated Voltage	3L/N/PE; 230/400V
	Max. Current	200A
	Frequency	50/60Hz
	Power Factor	1 leading ~ 1 lagging
	Harmonic	<3% @ Rated Power
System Parameters	Thermal Management	Water Chiller, Dehumidifier
	Fire Suppression System	Combined detector (CO/VOC/Heat/Smoke), Perfluorohexanone, Water Sprinkler System
	Communication	LAN/4G
	Dimension(W*D*H)	1000*1440*2390(mm)
	Weight	2450kg
	IP Rating	IP54
	Working Temperature	-20 ~ 55°C
	Humidity	0~95%RH(No condensation)
	Latitude	≤3000m
	Certification	UN38.3; IEC62619; IEC61000

## INSTALLATION DIMENSIONS

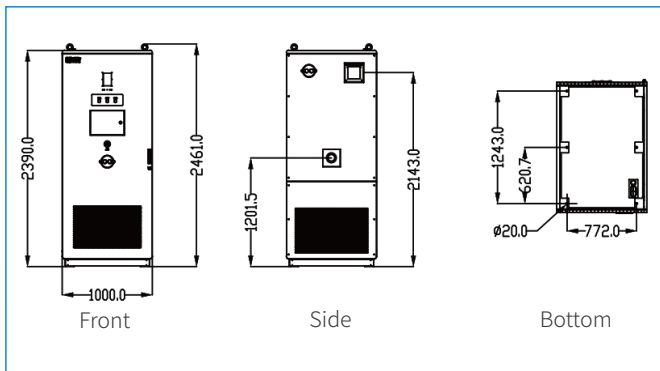

## TYPICAL APPLICATION

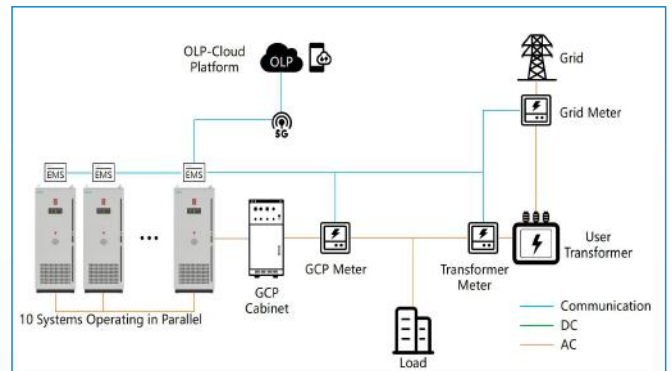

### OLiPower Energy & Automation Technology Co., Ltd

1001, Block A, Building 2, Shangzhi Technology Park, No.380 Guangming Avenue, Tangwei Community, Fenghuang Street, Guangming District, Shenzhen City, Guangdong Province

+86 (755) 2650 8686      sales@olipower.cn

\*OLiPower reserves the right of final interpretation, and is subject to modify without prior notice.

OLP-EIB-V832\_E261\_P125-LO



Welcome to follow  
Discover  
more company information